

# Tech Tub<sup>2</sup>® Modular Cart System



## Assembly Guide FTT401\_2016\_C

Check out our other products online at  
[www.copernicused.com](http://www.copernicused.com)

For assistance, please contact us:

**1-800-267-8494**

Email [info@copernicused.com](mailto:info@copernicused.com)

Have your packing slip ready for reference

## WARNING !

- This product is meant to be assembled by an adult.
- In its unassembled state, small parts present a hazard.
- To be used under direct supervision of an adult.

### 24 Device Cart (FTT624 or FTT624-USB)

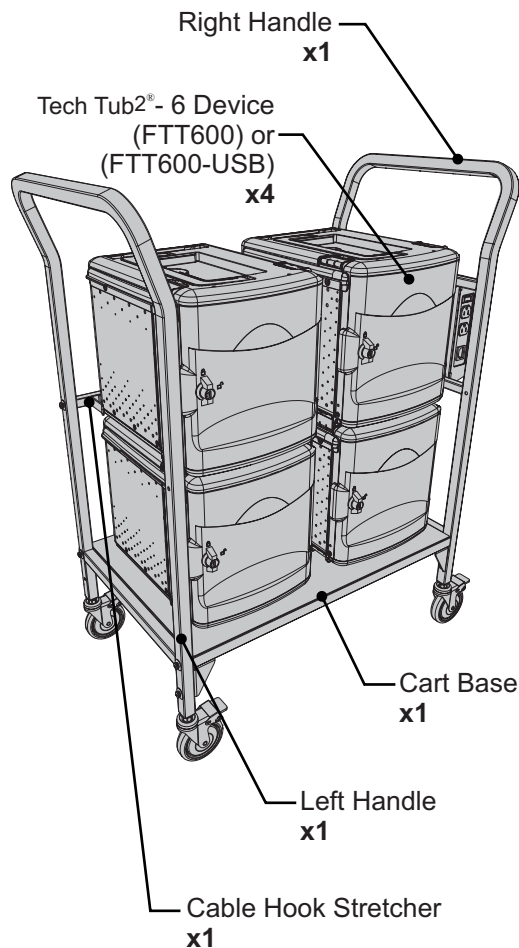

### 32 Device Cart (FTT632 or FTT632-USB)

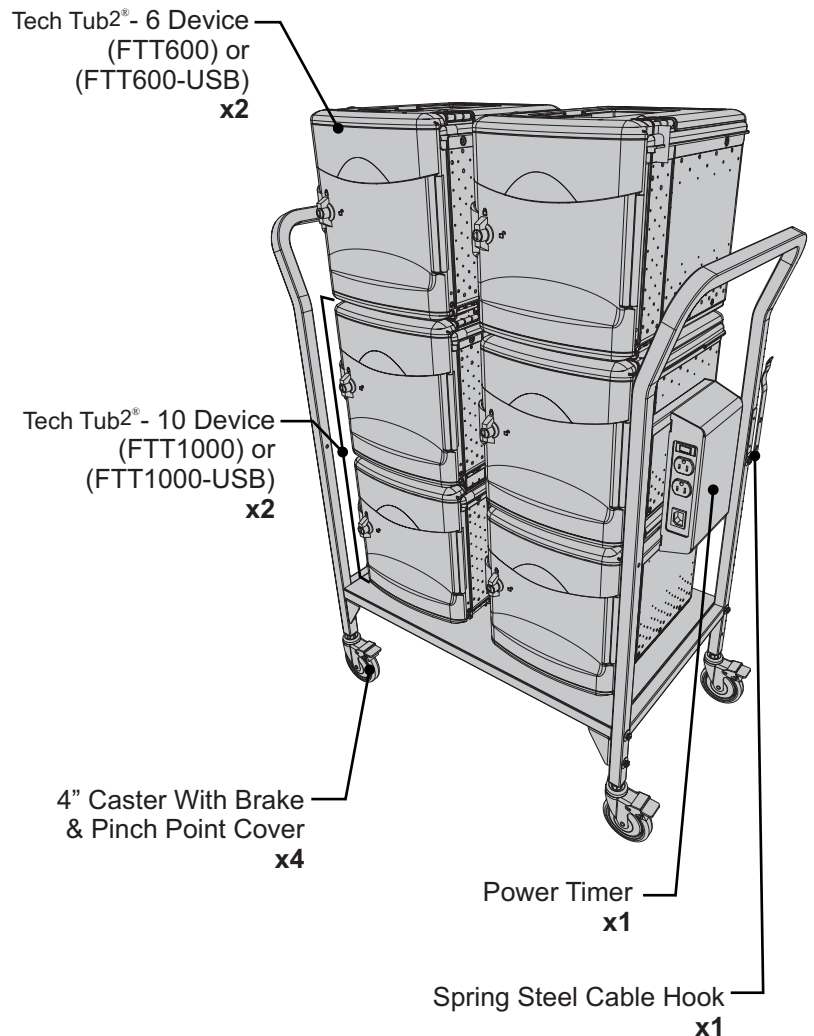

# Tech Tub<sup>2</sup>® Modular Cart System



## Assembly Guide FTT401\_2016\_C

Check out our other products online at  
[www.copernicused.com](http://www.copernicused.com)

For assistance, please contact us:

**1-800-267-8494**

Email [info@copernicused.com](mailto:info@copernicused.com)

**Have your packing slip ready for reference**

Dear Educator,

Thank you for purchasing one of our products. I hope that the Tech Tub<sup>2</sup>® Modular Cart System is useful in your classroom.

If you have any questions, concerns, or ideas please contact us by telephone at 1-800-267-8494 or email at [info@copernicused.com](mailto:info@copernicused.com).

*Jim Phillips*  
Chief Cook and Bottle Washer



We do not inherit the earth from our ancestors, we borrow it from our children.

NORTH AMERICAN  
PROVERB

Change is the end result of all true learning.

LEO BUSCAGLIA

What you leave behind is not what is engraved in stone monuments, but what is woven into the lives of others.

PERICLES

Education is the most powerful weapon which you can use to change the world.

NELSON MANDELA



### Validate Your Warranty

To validate your warranty, submit the ON-LINE form at [www.copernicused.com](http://www.copernicused.com)  
**Enter a draw to win a Copernicus Product for your classroom at the same time!**

# Tips for Assembly

## Watch for These Helpful Symbols

This symbol denotes a 2-Person Task. For safety, please ensure that there are the suggested number of people working on steps displaying this symbol.



Watch for this symbol throughout the Assembly Guide. Wherever you see it, pay close attention. The symbol denotes a step needing extra attention to ensure it is done correctly.



The star symbol highlights an advisory note.



## Before You Begin

- Lay out and identify all of the included parts.
- The hardware has been packed according to step.
- Read the assembly guide over once to familiarize yourself with them.



**!** Please note that in its unassembled state, this product contains parts that can be hazardous to small children. This product should be assembled by an adult.

## As You Assemble the Unit

- Follow the steps in sequence.
- Before beginning each step, find the part(s) that you need for that step.
- Pay attention to the labels on the parts; they are there to help direct you at certain stages.
- The title of each step states what you will be doing. Review the text and the pictures as you build the unit.

# Customer Service - FAQ's



**For missing parts and other issues regarding this product:**  
- I lost the key to, how can I get a new one?

*Please call Copernicus Customer Service, where we will be happy to help.  
1-800-267-8494. Monday - Friday 8:30am - 4:30 pm EST.*

*OR  
Email our Tech Support Service at [info@copernicused.com](mailto:info@copernicused.com)*

**Need Tech Support?  
Have a Question?**



*Email our Tech Support Service*

**Check out some of our  
other great products!**



*[www.copernicused.com](http://www.copernicused.com)*



# Warning! Hazard Risks!

Please read the warnings below for important safety information regarding your product. Failure to read these warnings or to follow the instructions below could result in personal injury or damage to your product that could void your warranty.



Small Parts

In its unassembled state, this product contains parts that can be hazardous to small children. This product should be assembled by an adult.



Adult Supervision

This product is to be used under the supervision of an adult.



Indoor Use Only

This product is intended for indoor use only. To reduce the risk of fire or electric shock, do not expose this product to rain or moisture. The internal components are not sealed from the environment.



Power Strip Specifications

Read your power strip electrical specifications. Only plug in devices that are approved for use with this power strip. Connect the supplied power strip directly to a wall outlet. **Do not connect to another power strip or use an extension cord.** Unplug when not in use. **Do not leave this product plugged in for more than 72 consecutive hours.** Turn off power strip before unplugging.

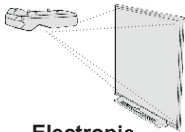

Electronic Equipment

Read the electrical specifications of any electronic equipment you are using with your Copernicus products. Failure to read these specifications and follow their instructions could result in damage to your equipment or personal injury.



Cable Trip Hazard

Ensure that any cables extending across the floor to your product are properly bundled and marked to avoid tripping or falling which may lead to personal injury.



Electrical Shock

Do not install or use the electrical components of this unit during a lightning storm.



Climb Hazard

Do not climb on, hang from or suspend objects from any components of your product unless otherwise specified.

# Tech Tub<sup>2</sup>® Modular Cart System

**Before beginning, you should have:**

**Contents - FTT401-0**

Left Handle x1

Right Handle x1

Cart Base x1

Cable Hook Stretcher x1

4" Caster With Brake & Pinch Point Cover 4x

Power Timer Mounting Bracket x1

Power Timer Cover x1

Spring Steel Cable Hook x1

**In Box 1**

**Hardware Actual Size**

**A** Hex Bolt - M6 x 40mm x6

**B** Hex Bolt - M6 x 35mm x2

**C** Hex Bolt - M5 x 15mm x4

**D** Allen Key Screw - M5 x 15mm x2

**E** M6 Star Washer x18

**F** M12 Lock Washer x4

**G** M12 Flat Washer x4

**H** M5 Thumb Nut x4

**I** M6 x 10mm Thumb Screw x2

**J** Zip Tie x2

Caster Wrench Not to Scale x1

M5/M6 Hex Wrench Not to Scale x1

Allen Key Not to Scale x1

**Contents - Box 2**

**Note:** Power Timer will be shipped inside the box labeled:  
 FTT600-D (For FTT632 & FTT632-USB)  
 FTT600-F (For FTT624)  
 FTT600-G (For FTT624-USB)

PowerTimer & Cable x1

24 Device Cart Use with SKU FTT624 or FTT624-USB

32 Device Cart Use with SKU FTT632 or FTT632-USB

OR

Tech Tub<sup>2</sup>® - 6 Device (FTT600) x4

Tech Tub<sup>2</sup>® - 6 Device (FTT600) x2

Tech Tub<sup>2</sup>® - 10 Device (FTT1000) x2

1

Actual Size:

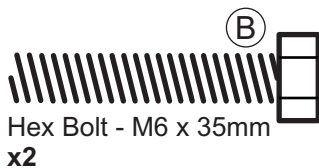
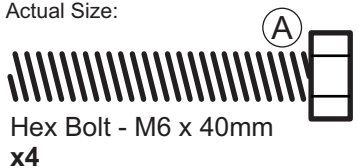

You will need: (Not to Scale)  
Cart Base  
x1

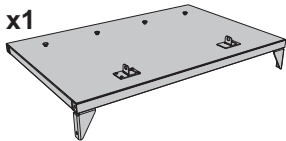

Left Handle  
x1

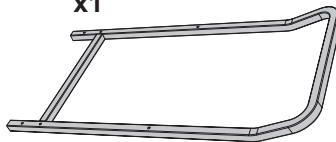

Right Handle  
x1

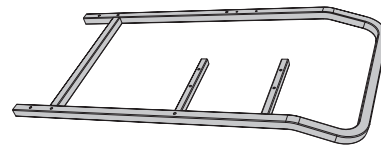

## Attach the Left and Right Side Handles

Stand base up on front edge and attach handles

**!** M6 Star Washer x6

Please note, star washers are critical components for electrical safety. Star washers must be included and fasteners fully tightened to prevent the risk of electric shock.

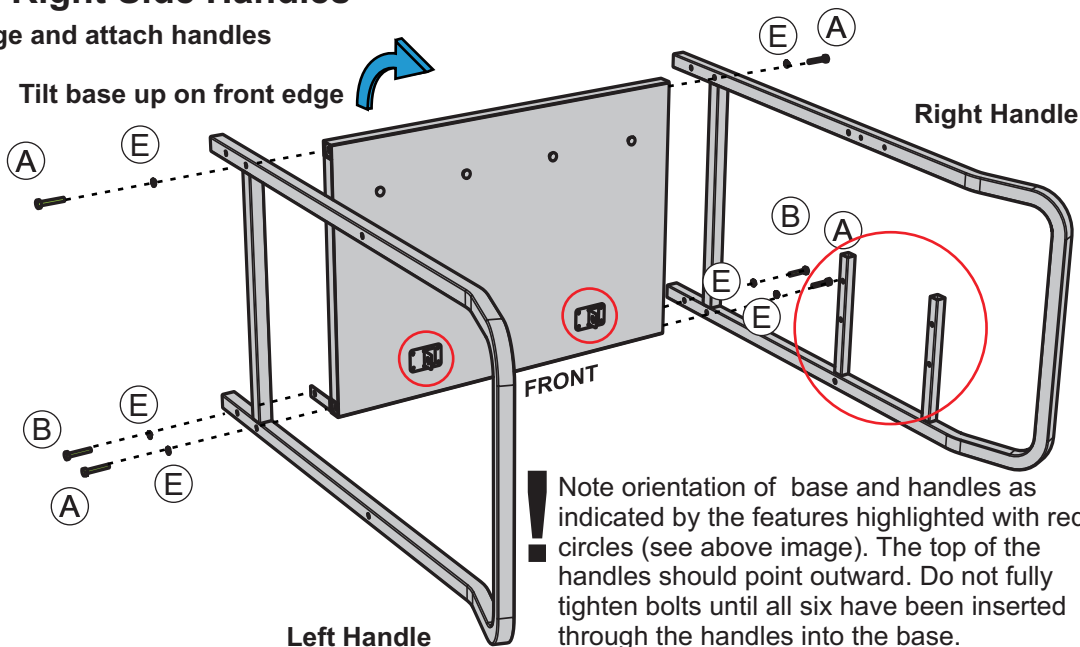

2

Actual Size:

You will need: (Not to Scale)

4" Caster With Brake & Safety Pinch Point Cover  
4x (41013)

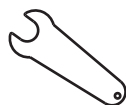

Caster Wrench  
x1

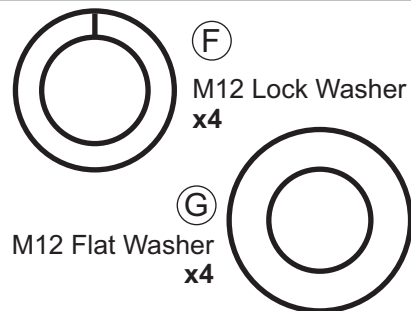

## Attach Casters

Lock casters before installing them

**!** Note  
Lock the caster by pressing down on the black tab. This will enable you to screw the caster into the tube quickly. Use the caster wrench to tighten the caster fully. After casters are installed return cart to upright position.

Check casters every 6 months and tighten as needed.

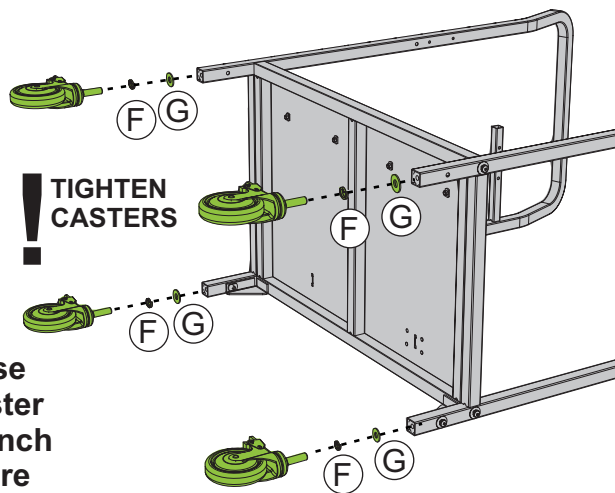
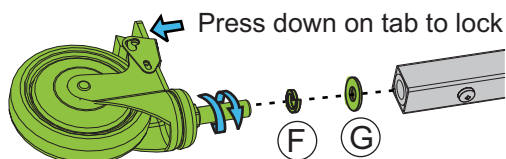



3

Actual Size:

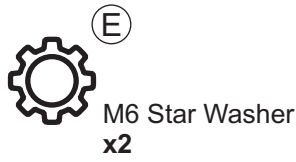

You will need: (Not to Scale)

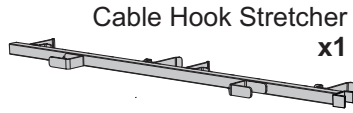

### Attach The Cable Hook Stretcher

① Position Cable Hook Stretcher so it aligns with holes on handle

**!** Note  
Ensure cable hooks point toward back of cart

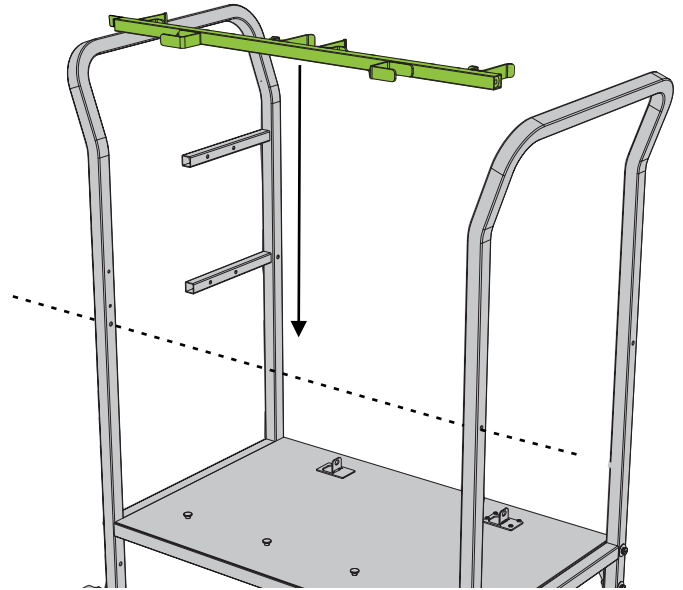
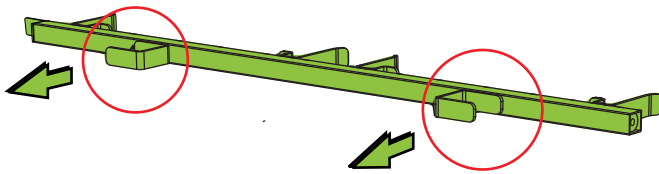

② Fasten Cable Hook Stretcher to Handles

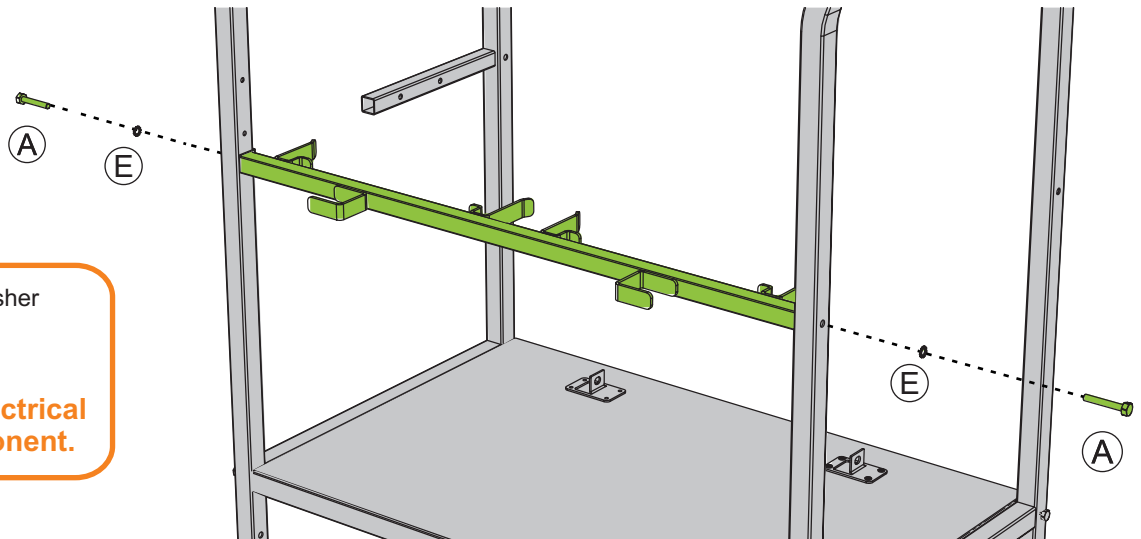

**!** **E** M6 Star Washer  
x2

**Important electrical safety component.**

4

Actual Size:

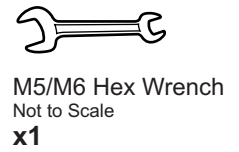
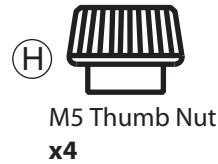
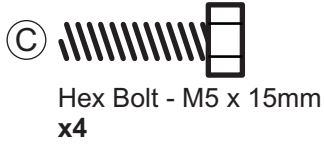

You will need: (Not to Scale)

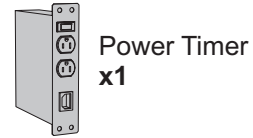
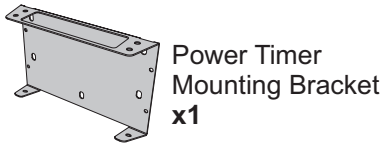

## Install Power Timer

① Fasten Mounting Bracket to Right Handle

② Fasten Power Timer to Mounting Bracket

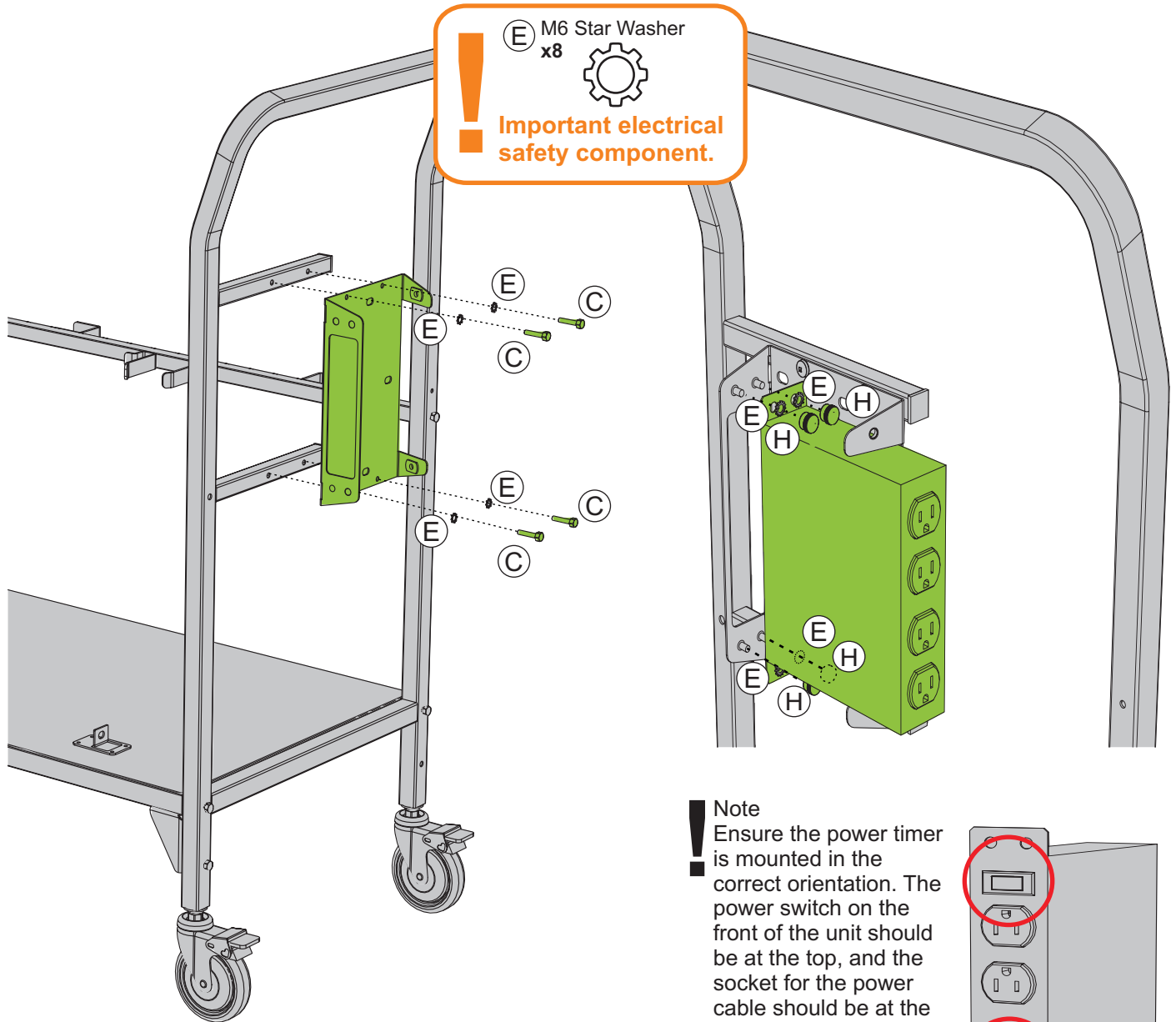

⚠ **Important electrical safety component.**

E M6 Star Washer x8

**Note**  
 Ensure the power timer is mounted in the correct orientation. The power switch on the front of the unit should be at the top, and the socket for the power cable should be at the bottom (please see image to the right).

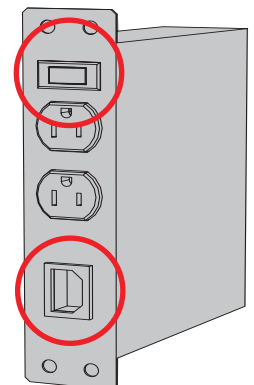

Cont. on Next Page...



# 4 cont.

Actual Size:

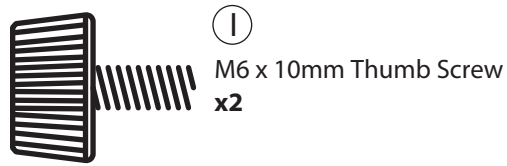

You will need: (Not to Scale)

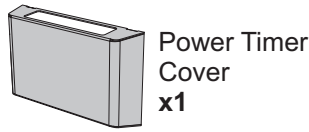

## Install Switching Power Timer

③ Hook Power Timer Cover Onto Mounting Bracket

④ Fasten Power Timer Cover to Mounting Bracket

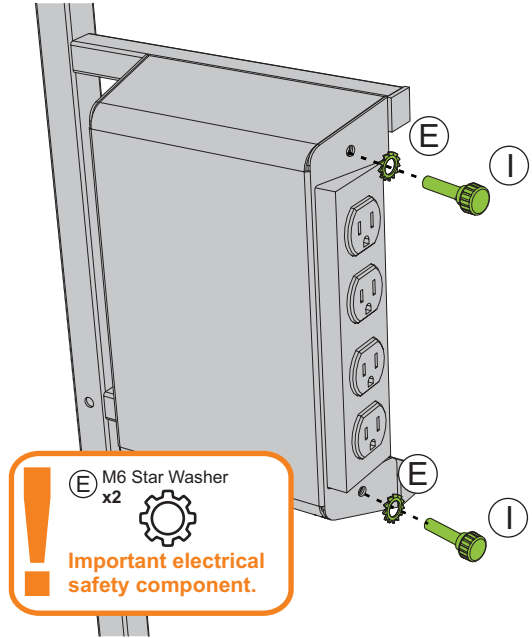
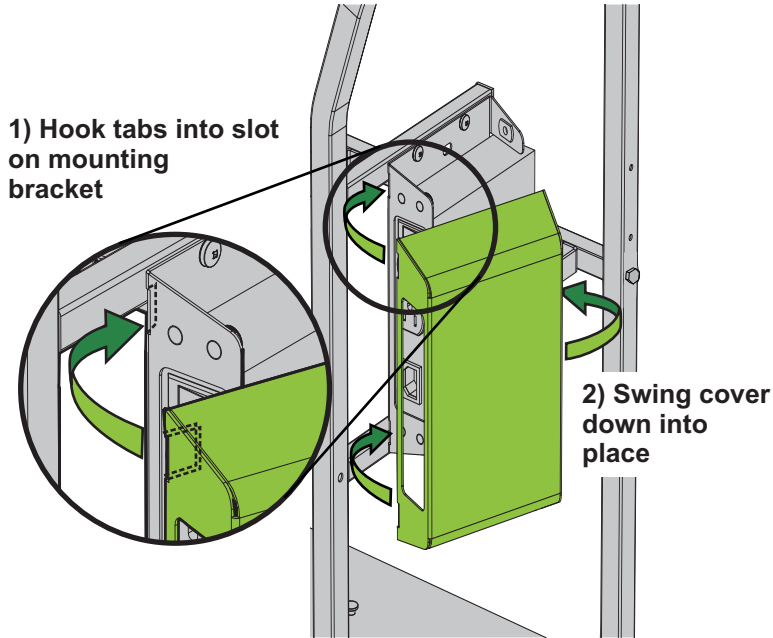

# 5

Actual Size:



You will need: (Not to Scale)



## Install Spring Steel Cable Hook

Fasten to Right Handle at the Back

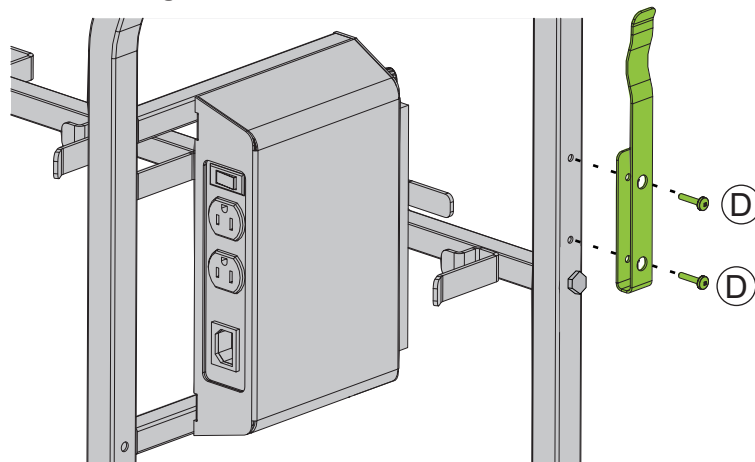

**!** Before proceeding to the next step please check the entire assembly for loose parts; tighten all casters, bolts, screws and nuts.

Tighten all casters using supplied Caster Wrench.

Keep wrench with unit. Casters must be tightened every 6 months for proper maintenance.

# 6

You will need: (Not to Scale)

**Note:**  
Please follow the assembly instructions that accompanied your Tech Tub<sup>2</sup> to get it ready for installation on the Cart.

Tech Tub<sup>2</sup>® - 6 Device (FTT600)  
x2

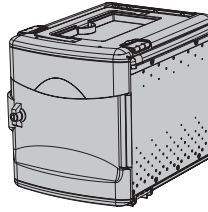

OR

Tech Tub<sup>2</sup>® - 10 Device (FTT1000)  
x2

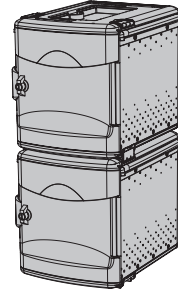

## Install Tech Tub<sup>2</sup>® onto Cart

Insert the rear feet of the Tech Tub<sup>2</sup>® onto the metal pins on the cart base and lower the front of the tub onto the metal tab at the front of the cart base. Repeat this process for the right side.

① Hook the rear feet onto the pins on the Cart Base.

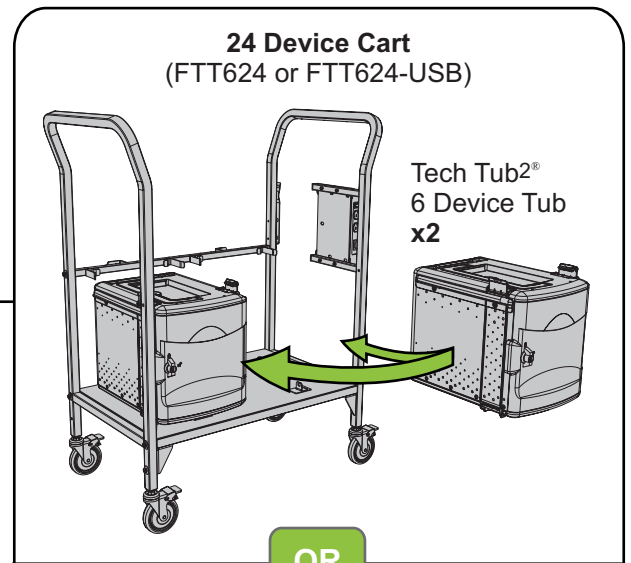
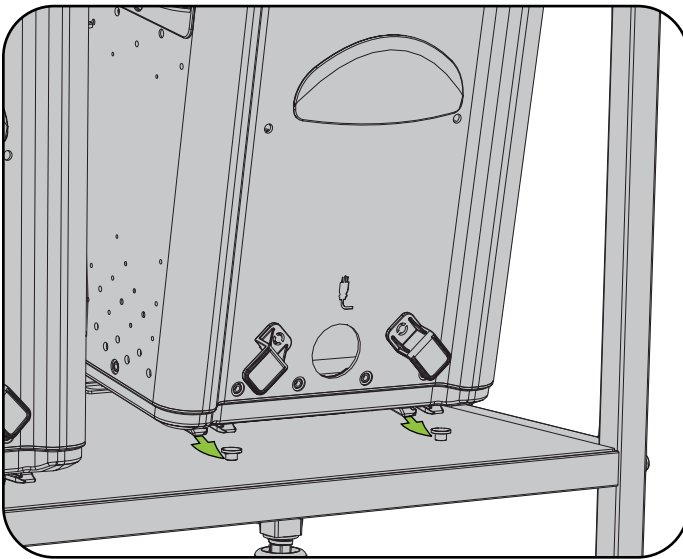

OR

② The slot on the front underside of the Tech Tub<sup>2</sup>® fits over the metal tab at the front of the Cart Base.

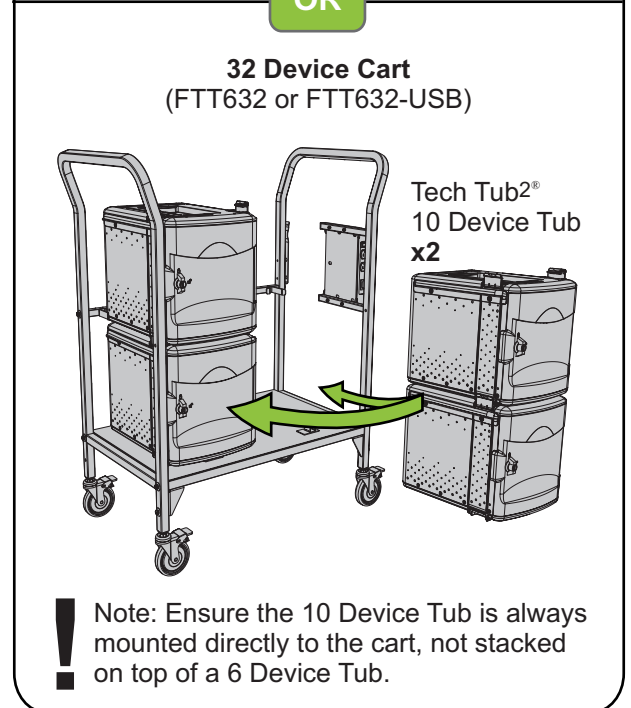
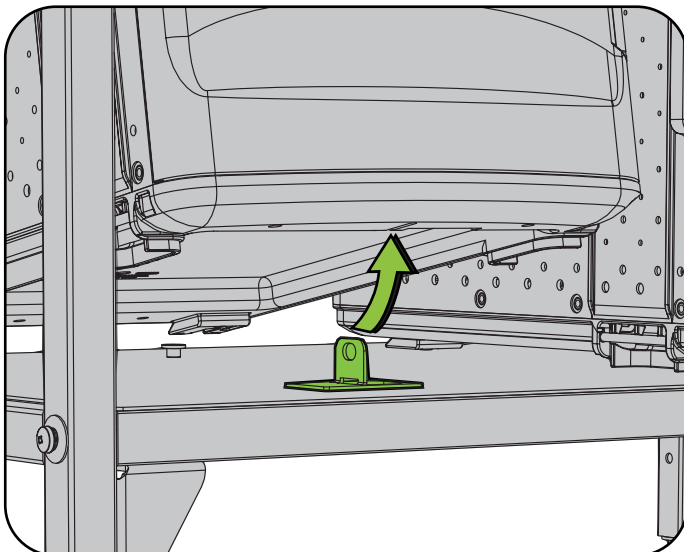

# 6 Cont.

Actual Size:

You will need: (Not to Scale)

## Install Tech Tub<sup>2</sup>® onto Cart

- ③ Open the front door of the Tech Tub<sup>2</sup>® and slide the metal locking pin through the metal tab.

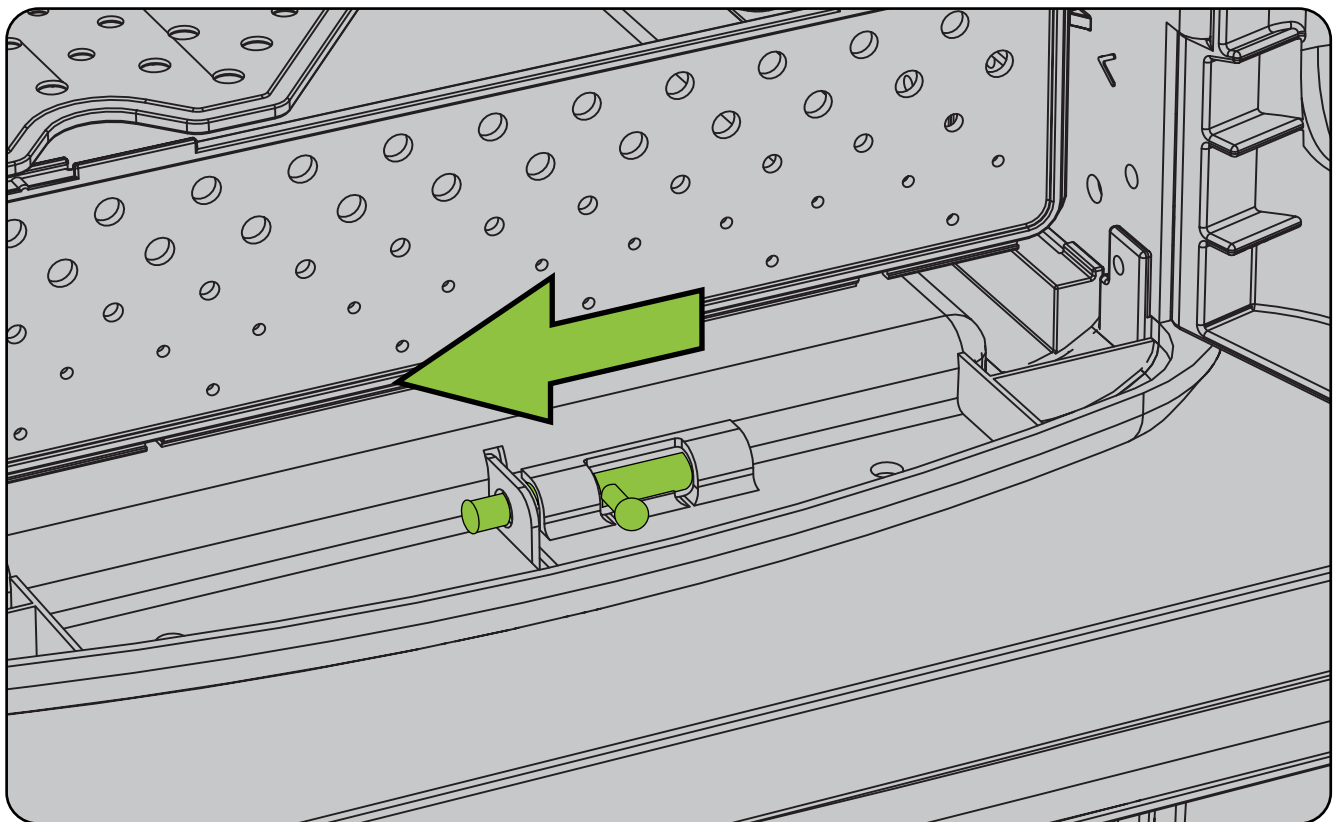
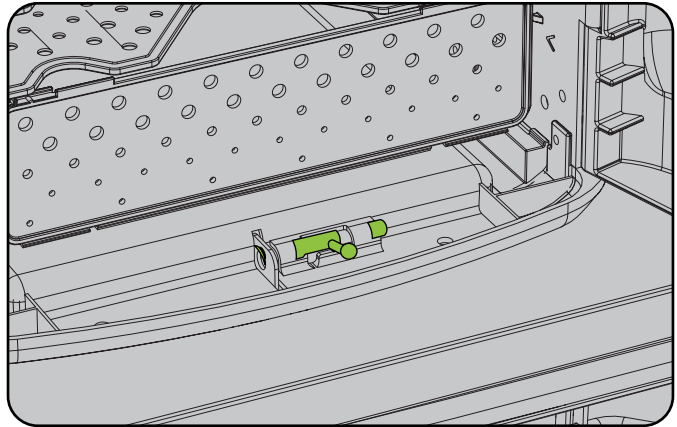
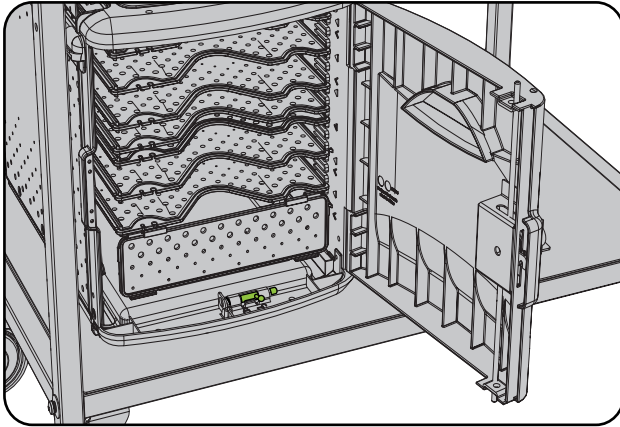

**NOTE:** The locking process is the same for both left and right positions on the cart.

# 7

You will need: (Not to Scale)

Tech Tub<sup>2</sup><sup>®</sup>  
6 Device  
(FTT600)  
x2

OR

Tech Tub<sup>2</sup><sup>®</sup>  
6 Device  
(FTT600)  
x2

Tech Tub<sup>2</sup><sup>®</sup>  
10 Device  
(FTT1000)  
x2

**Note:**  
This step is the same for connecting a 6 Device Tub to another 6 Device Tub, or a 10 Device Tub.

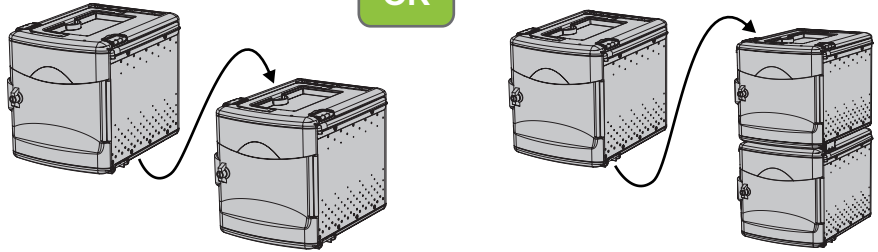

## Latching a Tech Tub<sup>2</sup><sup>®</sup> to Another Tech Tub<sup>2</sup><sup>®</sup>

- 1 Insert the back feet of the top Tech Tub<sup>2</sup><sup>®</sup> into the slot on the top of the lower tub that is already mounted on the cart.

**Note:** Ensure the flip lock on each side of the bottom tub is in the open position (as shown).

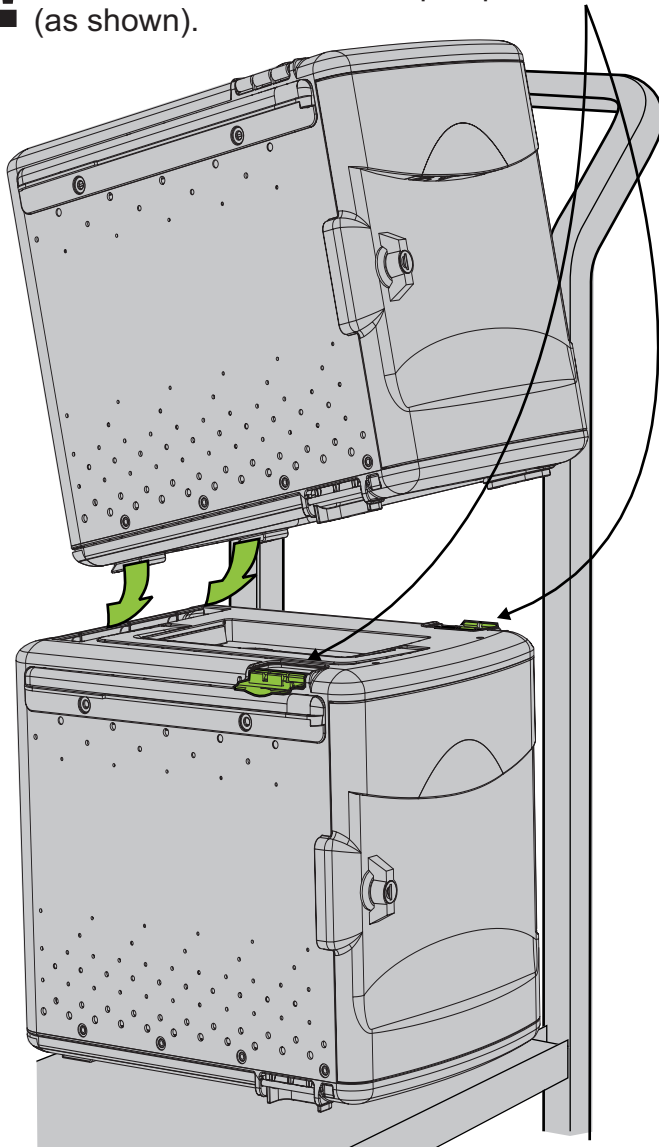

- 2 Insert the front feet of the top Tech Tub<sup>2</sup><sup>®</sup> into the front openings on the top of the lower tub.

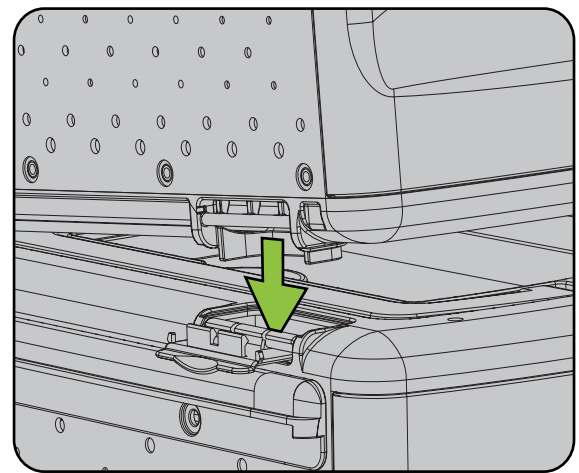

- 3 Lock the top and bottom Tech Tub<sup>2</sup><sup>®</sup> together using the flip locks on either side.

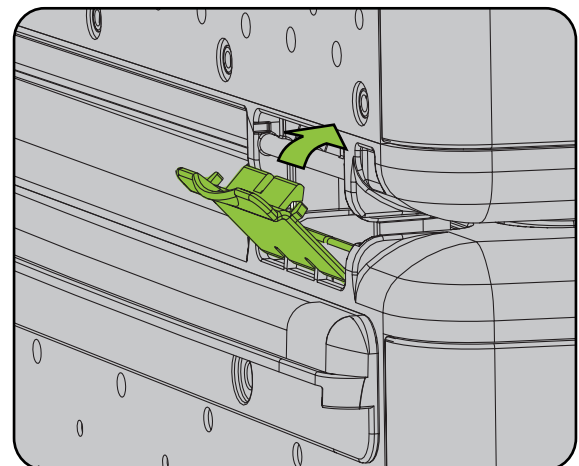

**Note:** SNAP the flip lock on each side of the Tech Tub<sup>2</sup><sup>®</sup> into place when closing it to ensure a secure connection.

# 8

You will need: (Not to Scale)

Power Cable  
x1

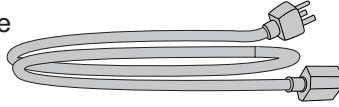

J



Zip Tie  
x2

## Attach Power Cable

① Plug power cable into Power Timer

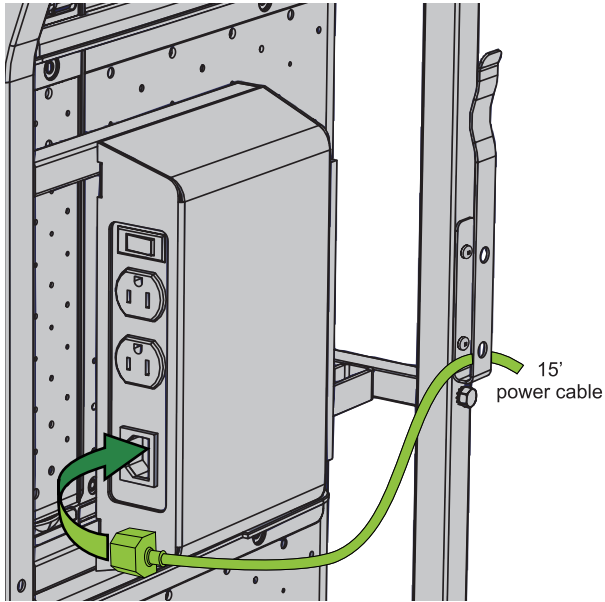

② Zip Tie Power Cable To Frame

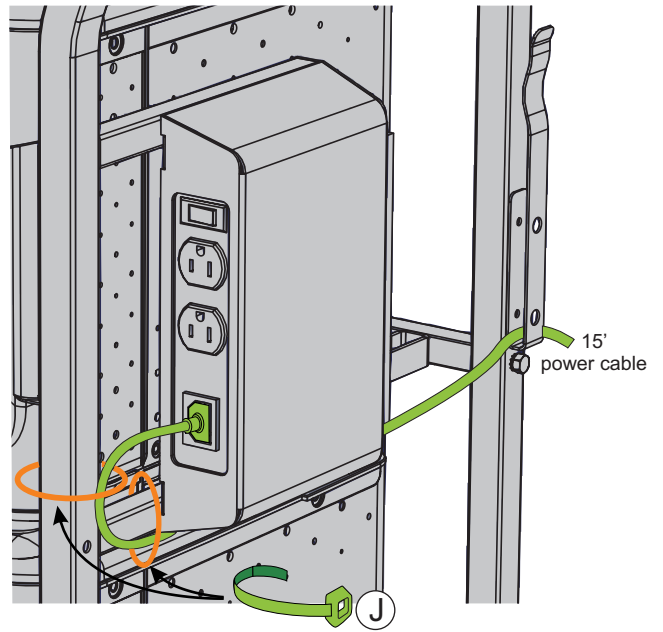

### ! Note

Leave some slack in cable when zip tying it to the cart to avoid excess strain on cable or power timer.  
Trim the ends of the zip ties once they are fully tightened around the power cable.

③ Wrap Power Cable On Cable Hook Stretcher Before Moving Cart

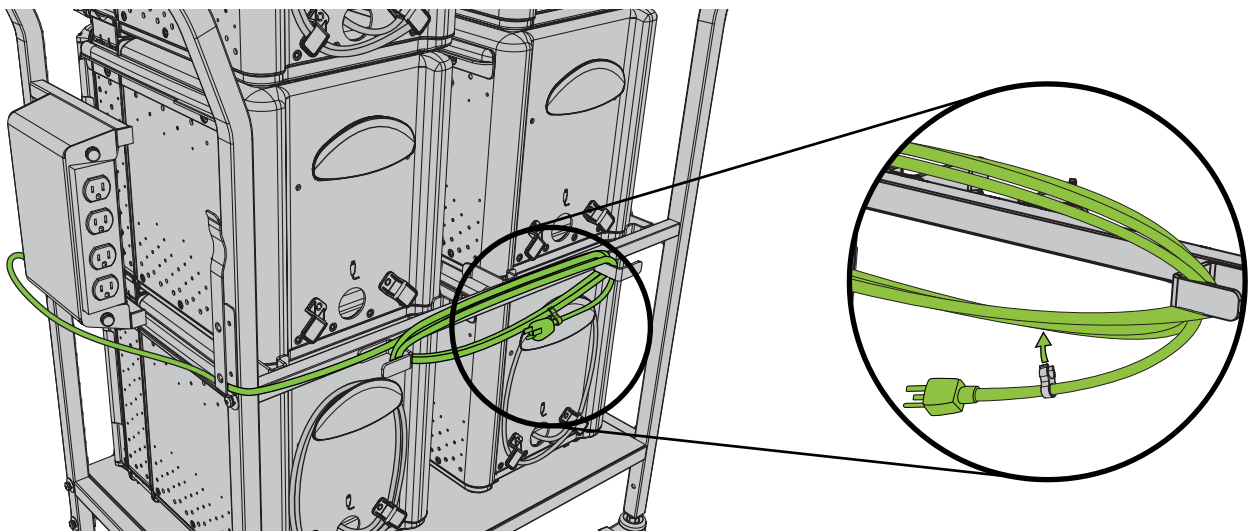

! Note: Use the attached clip to secure the power cable to itself before moving the cart.



You will need: (Not to Scale)

## Cable Management

Route Each Tech Tub<sup>2</sup>® Power Cable Through the Spring Steel Cable Hook and Plug It Into the Power Timer

### Note

- ! To keep the power cables organized keep the excess length of cable wrapped on the back of the Tech Tub<sup>2</sup>®.
- Ensure that there is enough slack to prevent unnecessary strain on the power cables or power timer.

