

TOP

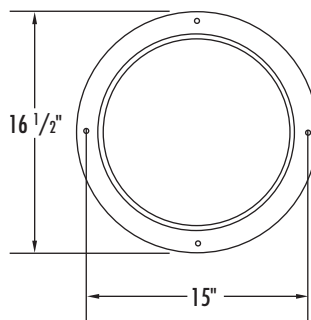

FRONT

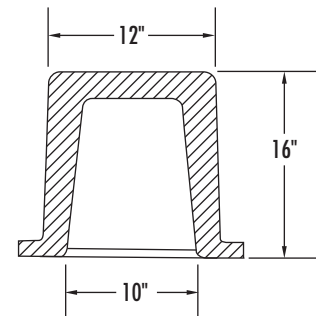

Model #: ATN500

Note: Dimensional tolerances are $\pm 1\%$ due to manufacturing process.

Overview

Floor mounted stool. Engineered for intensive use durability and proven suitable for continuous daily use in challenging environments. Impact resistant.

Fabrication:

Slightly textured maintenance free surface allows for easy cleaning. Made in the U.S.A.

Material:

Rotationally molded, specially formulated, fire-retardant, high-impact polyethylene with ultraviolet light stabilizers (to reduce fading). Chemically resistant to blood, vinegar, urine, feces, salt solution and chlorine solution. Premium TruColor™ material is fully compounded for superior color, fire retardancy and quality assurance. Unit is filled with rigid polyurethane foam for increased durability and sound absorption.



TruColor™

Performance Test Standards:

- Product tested to 1,000 static load.
- Product dynamic drop tested to a relative impact force of two times BIFMA 5.4 15.4.2 (500 lbs. from 18").

Flammability:

Compliant with the following flammability standards:

- State of California, Technical Bulletin No. 133, Flammability Test Procedure for Seating Furniture for Use in Public Occupancies.
- UL1056 Fire Test of Upholstered Furniture
- ASTM E1537 Test Method for Fire Testing of Real Scale Upholstered Furniture Items
- NFPA 261 Cigarette Ignition Resistance of Upholstered Furniture

Environmental Test Standards:



GREENGUARD and GREENGUARD Gold Certified by UL Environment. Product certified for low chemical emissions to UL 2818. UL.COM/GG.

Color:

Wild Berry, Meadow, Pine Cone, Mojave, Lagoon, River Rock, Canyon, Graphite, Sea Spray.

Weight:

9.5 lbs.

Assembly:

None required.

Installation:

Anchors required for permanently attaching to floor. Anchors not supplied by Norix.

Warranty:

5 year limited replacement warranty.

To maintain product integrity, products placed in storage prior to installation should be held in a climate controlled area similar to the room where the product will be used. Norix also recommends that any Attenda products shipped via ocean container maintain a temperature of 70-75°F with a Relative Humidity of 35%.

Maintenance / Cleaning Procedures:



Recommend using Norix Cleaning Solutions, specifically formulated for extended care of Norix products. Clean, Restore and Protect with Norix's 1-2-3 Care System for Molded Furniture.

Patents:

U.S. Mechanical Patents Issued and Pending. US Patent No. 8,007,059 B2

Filing System:

12600 Institutional Furniture
11197 Correctional Furniture