

norix®

FURNITURE

Engineered to Endure™

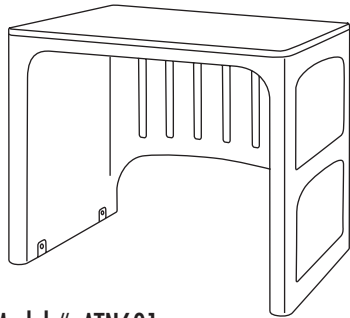

Model #: ATN601

Overview

Floor mounted desk. Engineered for intensive use durability and proven suitable for continuous daily use in challenging environments. Impact resistant.

Fabrication:

Base: Slightly textured maintenance free surface allows for easy cleaning.
Top: 45 lb. density M3 Grade particle board with embedded t-nuts for mechanically attaching top to base with a secure steel-to-steel connection. Made in the U.S.A.

Material:

Base: Rotationally molded, specially formulated, fire-retardant, high-impact polyethylene with ultraviolet light stabilizers (to reduce fading). Chemically resistant to blood, vinegar, urine, feces, salt solution and chlorine solution. Premium TruColor™ material is fully compounded for superior color, fire retardancy and quality assurance. Unit is filled with rigid polyurethane foam for increased durability and sound absorption.



TruColor™

Top: Decorative high-pressure laminate sealed with a specially formulated, highly durable molded edge. Edge is radiused for safety and pressure fused to the top, rendering it permanently non-removable and highly sanitary.

Flammability:

Compliant with the following flammability standards:

- State of California, Technical Bulletin No. 133, Flammability Test Procedure for Seating Furniture for Use in Public Occupancies.
- UL1056 Fire Test of Upholstered Furniture
- ASTM E1537 Test Method for Fire Testing of Real Scale Upholstered Furniture Items
- NFPA 261 Cigarette Ignition Resistance of Upholstered Furniture

Environmental Test Standards:



GREENGUARD and GREENGUARD Gold Certified by UL Environment. Product certified for low chemical emissions to UL 2818. UL.COM/GG.

Note: Dimensional tolerances are $\pm 1\%$ due to manufacturing process.

SIDE

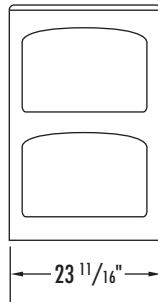

FRONT

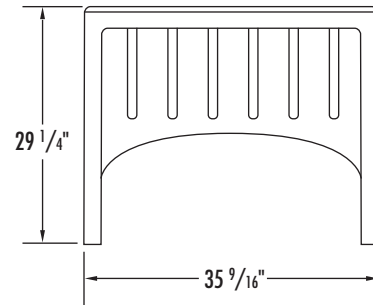

TOP

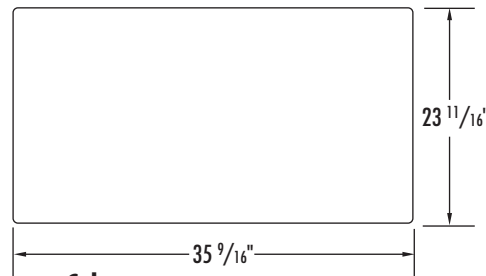

Color:

Base: Wild Berry, Meadow, Pine Cone, Mojave, Lagoon, River Rock, Canyon, Graphite, Sea Spray.

Top: Wilsonart® 10776-60 Kensington Maple, Wilsonart® 7816-60 Solar Oak, Wilsonart® 7054-60 Wild Cherry.

Weight:

60 lbs.

Assembly:

None required.

Installation:

See assembly instructions.

Warranty:

5 year limited replacement warranty.

To maintain product integrity, products placed in storage prior to installation should be held in a climate controlled area similar to the room where the product will be used. Norix also recommends that any Attenda products shipped via ocean container maintain a temperature of 70-75°F with a Relative Humidity of 35%.

Maintenance / Cleaning Procedures:

Recommend using Norix Cleaning Solutions, specifically formulated for extended care of Norix products. Clean, Restore and Protect with Norix's 1-2-3 Care System for Molded Furniture. Tops: Norix Cleaning Solutions' Wood Cleaner and Polish (W).



Patents:

U.S. Mechanical Patents Issued and Pending. US Patent No. 8,007,059 B2

Filing System:

12600 Institutional Furniture

11197 Correctional Furniture

norix®

Norix Group, Inc. • 1800 W. Hawthorne Lane, Suite N, West Chicago, IL 60185
Phone: 800-234-4900 • 630-231-1331 • Fax: 630-231-4343 • Email: furniture@norix.com • www.norix.com
Specifications subject to change without notice. ©2015 Norix Group, Inc. All Rights Reserved. Printed in U.S.A. 5/15

AT-7