



# *Treadmill Desk*

*Owner's Manual for models:*

*TR800-DT5*

*TR1200-DT5*

*TR5000-DT5*

## ***Welcome to LifeSpan Workplace!***

*Congratulations on stepping into the growing movement of workplace activity. You're joining an enthusiastic community, one that's dedicated to a gentle pace towards better living and more productive work environments.*

*You've picked the right partner. LifeSpan is the originator of active workstations and the global leader in safe and efficient workplace motion. We trust our mission will directly benefit your own, a task we don't take sitting down. With our company-wide dedication to quality and reliability, we're certain you'll be satisfied with your newfound health.*

*Before you assemble or operate your product, please read this manual thoroughly. Important information regarding safety precautions, product maintenance, assembly instructions, and proper operation are included.*

*We recommend you take a personal approach to adding movement to your day. Begin slowly, gently increasing your activity in a way that is both comfortable and enjoyable. We have a wealth of helpful information available on our website, feel free to use us as a resource as you utilize your new product. We'd love to share our strategies and provide you with proven methods for success.*

*Please thoroughly read this manual before you assemble or operate your treadmill. Neither LifeSpan nor its representatives can accept responsibility for any damages or injury incurred as a result of information presented in this manual except under the terms of the product warranty.*

# Contents

## *Getting Started*

<i>Warranty</i>	8
<i>Registration</i>	
<i>Safety First</i>	
<i>Children &amp; Pets</i>	
<i>Safety Tips While in Use</i>	

## *Treadmill Base*

<b>About Your Treadmill Base</b>	14
<i>Specifications</i>	
<i>Proper Grounding</i>	
<i>Power Cord Options</i>	

<b>Maintenance and Tips</b>	16
<i>Daily Cleaning</i>	
<i>Monthly Cleaning</i>	
<i>Safety and Integrity</i>	
<i>Belt Lubrication</i>	
<i>Belt Tensioning</i>	
<i>Belt Alignment</i>	
<i>Moving the Treadmill</i>	

## *DT5 Desk*

**Desk Assembly** 22

**Console Assembly** 32

**Final Connection** 36

*Treadmill to DT5 Desk Assembly*

**Leveling and Height Adjustment** 37

***Treadmill Desk Operations*** 39

*Specifications*

*Setting the Clock*

*Starting the Treadmill Desk*

*Console Buttons*

*Preset Speed Button*

*Bluetooth Operation*

*Innovative Features*

*Troubleshooting*

*Personal Settings*

*Display Details*

# *Getting Started*

## Getting Started

### Warranty

Your LifeSpan treadmill desk comes with the following limited warranty valid in North America.

Warranty Item	TR800-DT5	TR1200-DT5	TR5000-DT5
Frame	Lifetime	Lifetime	Lifetime
Motor	3 Years	3 Years	3 Years
Parts	1 Year	2 Years	2 Years
Labor	1 Year	1 Year	1 Year

LifeSpan warrants the equipment it manufactures is free from defects in materials and workmanship under normal use and services. The periods above are based on the date of purchase. During these periods, LifeSpan will repair or replace any defective part. Free labor is included on all parts that are not normally assembled or replaced by the customer within the labor period.

LifeSpan reserves the right to make changes and improvements to our products without incurring any obligations to similarly alter any product purchased. In order to insure our product warranty and to ensure the safe and efficient operation of your LifeSpan product, only authorized parts can be used. The warranty is void if any parts other than those provided by LifeSpan are used.

#### Exclusions and Limitations:

- This warranty does not apply to any defects caused by negligence, misuse, improper assembly, or maintenance, accident, or “act of God.”
- This warranty does not apply to discoloration of paints or plastics.
- LifeSpan shall not be responsible for incidental or consequential damages.
- This warranty is non-transferable from the original owner.

### Registration

Should you need to process a warranty claim make sure you retain your purchase receipt to verify the date of purchase and register your LifeSpan product online.

### Safety First

When using active workstations, basic precautions should always be followed, including:

- Never drop or insert any object into any opening. If an object falls into an opening, turn the power off and unplug the power cord from the outlet.
- Never operate this treadmill if it has been damaged or partially submerged in water.
- To reduce the risk of electric shock, unplug the treadmill from the wall outlet when not in use, before performing any maintenance, or before moving the treadmill.
- Do not use outdoors or in areas of high humidity or extreme temperature changes.
- Do not operate where aerosol spray products are being used or where oxygen is being administered.
- Never place the power cord under carpeting or place any object on top of the cord, this may pinch or damage the cord causing fire damage or personal injury.
- Use this product for its intended use as described in this Owner's Manual. Do not use attachments that are not recommended by LifeSpan.
- Do not leave your treadmill running while not in use.

### Children and Pets

- Keep children from playing on your treadmill at all times.
- When in use children and pets should be kept at least 10 feet (3m) away.
- This treadmill should only be used by those 12 years of age and older. Users, especially those with known health conditions, should consult a physician prior to beginning an activity program..
- Cleaning and user maintenance shall not be made by children without supervision.

## Getting Started

### Safety Tips While in Use

- Always consult a physician before beginning an exercise program.
- If you experience chest pains, nausea, dizziness or shortness of breath, stop exercising immediately and consult your physician before continuing. Do not wear clothing or jewelry that might catch on any part of the treadmill.
- Wear shoes with high traction rubber soles. Do not wear shoes with heels, leather soles, cleats or spikes.
- Do not walk or run backwards on the treadmill, always face forward.
- Allow the running belt to fully stop prior to getting off the treadmill.
- Make sure the area behind the treadmill remains completely clear during use. A minimum of 3 feet (1m) of clearance is required for safety reasons. There should be a minimum of 2 ft. (.6 m) on at least one side of the treadmill.

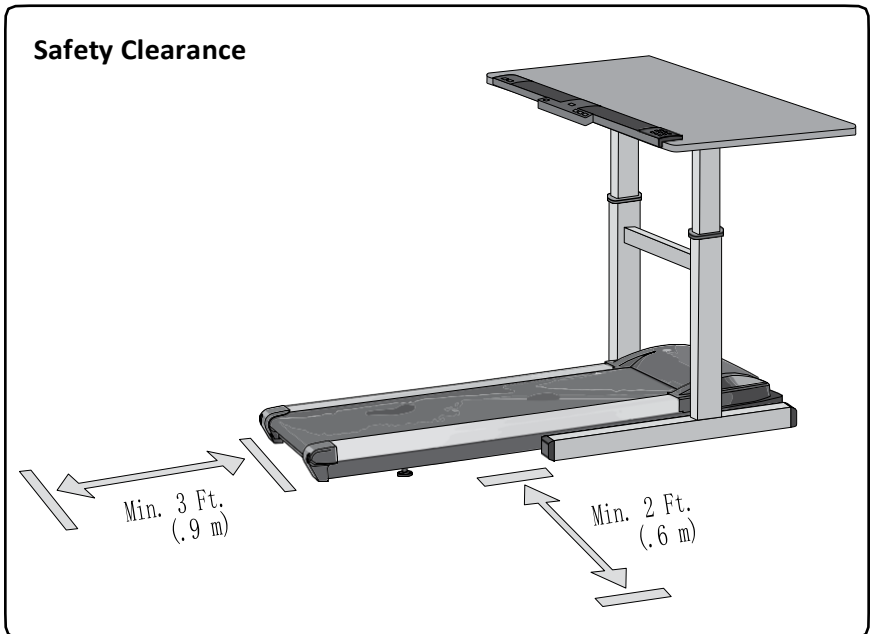

Note: Read all instructions and save for future reference.



## ***Treadmill Base***

## About Your Treadmill Base

### Specifications

#### TR800B

Speed Range	0.4 - 4.0 mph (0.6 - 6.4 kph)
Walking Belt Size	18" x 45" (45.7 cm x 111.7 cm)
Roller Size	Tapered Front 2.4" (6 cm), Rear 2.0" (5 cm)
Deck	3/4" (1.9 cm) Phenolic Deck
Deck Suspension	6 Independent Compression Shocks
Drive Motor	2.0 HP Continuous Duty DC
Max User Weight	300 lbs. (136 kg)
Dimensions	60.5" L x 26" W (153.6 cm x 66 cm)

#### TR1200B

Speed Range	0.4 - 4.0 mph (0.6 - 6.4 kph)
Walking Belt Size	20" x 50" (51 cm x 127 cm)
Roller Size	Tapered Front 2.4" (6 cm), Rear 2.0" (5 cm)
Deck	3/4" (1.9 cm) Phenolic Deck
Deck Suspension	6 Independent Compression Shocks
Drive Motor	2.25 HP Continuous Duty DC
Max User Weight	350 lbs. (159 kg)
Dimensions	64" L x 29" W (160 cm x 73.7 cm)

#### TR5000B

Speed Range	0.4 - 4.0 mph (0.6 - 6.4 kph)
Walking Belt Size	20" x 50" (51 cm x 127 cm)
Roller Size	Tapered Front 2.4" (6 cm), Rear 2.0" (5 cm)
Deck	1" (2.5 cm) Phenolic Deck
Deck Suspension	6 Independent Compression Shocks
Drive Motor	3.0 HP Continuous Duty DC
Max User Weight	400 lbs. (182 kg)
Dimensions	64" L x 29" W (160 cm x 73.7 cm)

## About Your Treadmill Base

### Proper Grounding

LifeSpan equipment must be grounded. Improper connection of the equipment's grounding conductor can result in the risk of electric shock. Check with a qualified electrician or service person if you are in doubt as to whether the outlet is properly grounded. Do not modify the plug provided with the product or use a ground plug adapter to adapt to a non-grounded outlet. If the plug will not fit in the outlet, have the proper outlet installed by a qualified electrician.

### Power Cord Options

This treadmill should only be used with the proper power cord and power outlet. Several power cord options (shown below) are available from LifeSpan. We do our best to include the correct power cord with the treadmill for your area. In the event that the correct power cord is not included in the packaging please contact your local distributor.

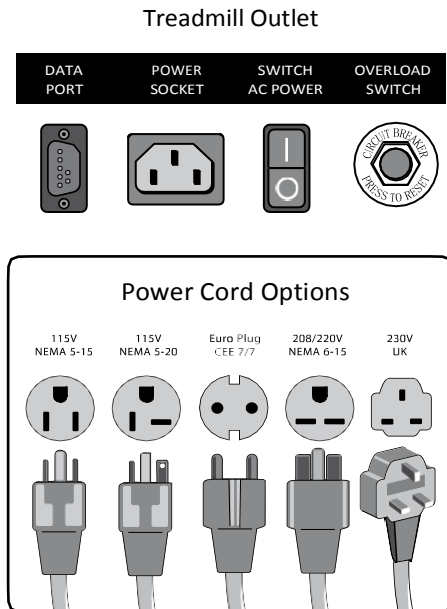

Do not use extension cords between the treadmill and power outlet.



Do not plug into a GFI outlet or circuit as it may trip the breaker.

## Maintenance and Tips

### Daily Cleaning

It is recommended to wipe the treadmill down after each use to keep the treadmill clean and dry. A mild detergent may be used at times to help remove all dirt and salt from the belt, painted parts and the display.

### Monthly Cleaning

This cleaning includes removing the motor cover and cleaning around the motor and electronics. It is recommended to clean the motor compartment if the treadmill is in an area where there might be plush carpet fibers that could get pulled up into the motor compartment. It is a good idea at this time to tighten all assembly hardware and check power cord for damage, or anything else that would indicate the need for service.

### Safety and Integrity

The safety and integrity designed into the machine can only be maintained when the treadmill is regularly examined for damage and repaired. Worn or damaged components shall be replaced immediately or the treadmill be removed from service until the repair is made. Pay special attention to components most susceptible to wear.



**WARNING:** Keep treadmill stable on flat ground.



**WARNING:** Unplug the power cord before removing the motor cover.

**IMPORTANT:** If service is required, turn the power off and remove the power cord to ensure the unit cannot be used. Let all other users know the treadmill needs service.

**CAUTION:** Acidic cleaning detergents may damage painted or powder coated surfaces and should not be used. Such cleaners may void the LifeSpan warranty.

### Belt Lubrication

Use only 100% silicone and avoid using aerosol silicone sprays which include additives and petroleum distillates. One ounce of silicone should be used for each application.

The walking belt comes pre-lubricated from the factory. The TR800B and TR1200B should be lubricated every 50 hours of use. The TR5000B comes with a maintenance free belt and doesn't require lubrication.

To lubricate, unplug your TR800B and TR1200B. Slide your hand under the belt and lift the belt away from the deck. Apply about a dozen sprays toward the center of the belt from each side. Rotate the belt 1/3 and repeat this application. Rotate another 1/3 and repeat once more. Plug the treadmill in and walk for a few minutes to disperse lube evenly.

**NOTE:** When lubricating the belt, make sure the treadmill is on a surface that can be easily cleaned. After lubricating clean any excess silicone off the walking surface of the belt and side rails.

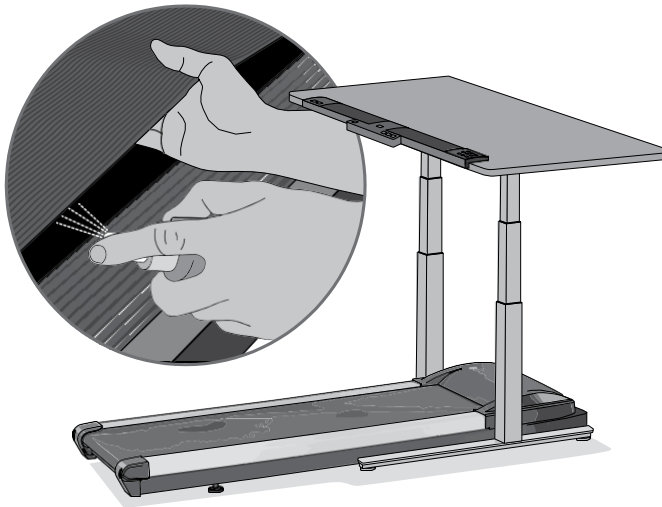

## Maintenance and Tips

### Belt Tensioning

If the belt begins to slip and needs to be tensioned, tension bolts are accessible from the back of the treadmill. Before tensioning the belt, start the treadmill and set the speed to 3 mph (5 kph).

- A. Using a 6 mm Allen wrench, included in your hardware bag, turn the right and left tension bolts 1/2 turn clockwise.
- B. Test to see if the slipping is eliminated. If the belt slips repeat step A and test again.

Note: Adjusting one side more than the other will cause the belt to drift to the side of the treadmill and will require belt alignment. Check to be sure the running belt is still aligned. If belt alignment is off as shown below, refer to Belt Alignment section.

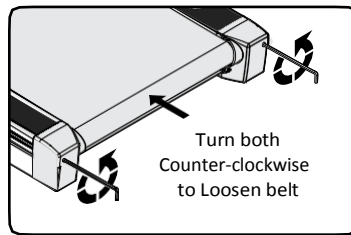
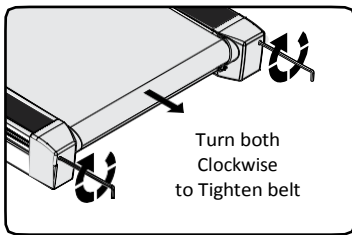

**CAUTION: DO NOT** tighten more than 2 full turns on each side. Over tensioning the belt can cause unnecessary friction and wear and tear on the belt, motor and electronics.

### Belt Alignment

- A. Press Start, then increase the treadmill speed to 3 mph (5 kph).
- B. Stand behind the treadmill to see which way the belt is drifting.
- C. If the belt drifts to the left, turn the left adjustment bolt 1/4 turn clockwise and the right adjustment bolt 1/4 turn counter-clockwise. (See FIG. 1)
- D. If the belt drifts to the right, turn the left adjustment bolt 1/4 turn counter-clockwise and the right adjustment bolt 1/4 turn clockwise. (See FIG. 2)
- E. Observe the alignment for two minutes. Repeat steps A-D as needed.

### Belt Alignment (continued)

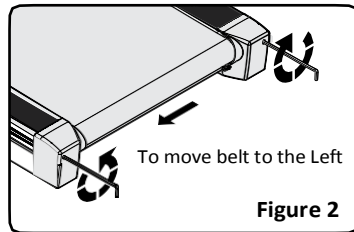
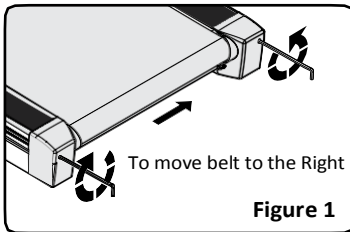

### Moving the Treadmill

1. Make sure the ON/OFF switch is turned OFF. Unplug the power cord and data cable from the treadmill.
2. Make sure nothing is on or near your treadmill which might spill, be knocked off, or prevent the treadmill from moving.
3. Place both hands under the support bar located under the back of the walking belt to make sure you have a solid lifting point.
4. Lift the back of the treadmill and roll to the desired location.

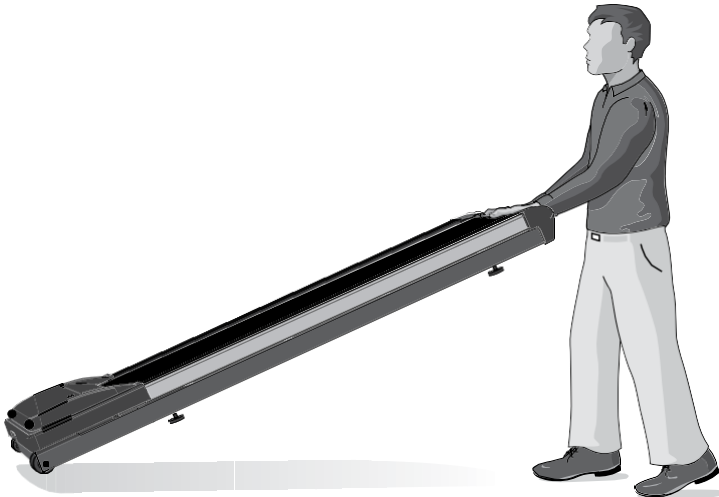

**CAUTION:** When lifting, use proper safety precautions and lifting techniques. Bend your knees and elbows, keep your back straight and lift evenly with both arms.

***Desk***

***DT5***



# Desk Assembly

At LifeSpan we strive to make our equipment easy to assemble and use.

Prior to starting the assembly process, take all the parts out of the box, remove plastic bags, and lay everything out on the floor to become familiar with the components.

Since your desk is a heavy piece of equipment, it is recommended that you use two people during assembly and follow these assembly instructions to reduce any problems that may occur.

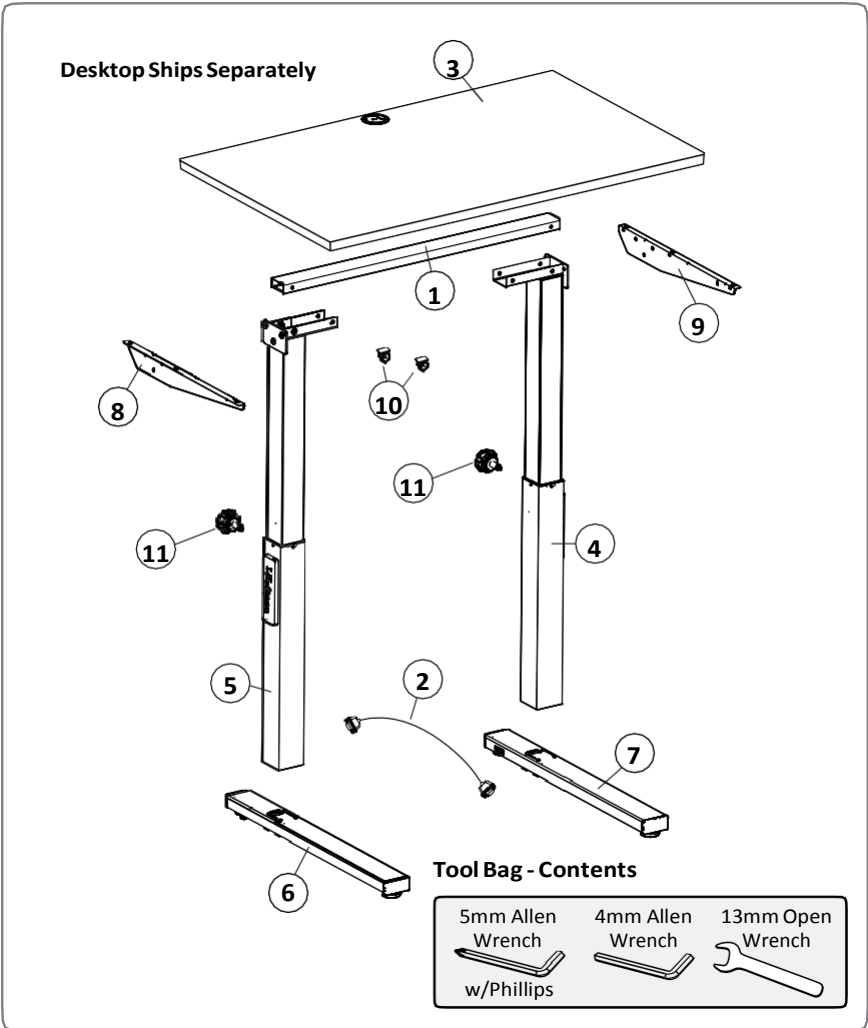

# Desk Assembly

## Hardware Included

Item#	Part Description
1	Reinforcement Frame
2	Data Cable
3	Desktop
4	Right Leg
5	Left Leg
6	Left Base Foot
7	Right Base Foot

Item#	Part Description
8	Left Desk Support Bracket
9	Right Desk Support Bracket
10	Cable Routing Ties
11	Height Adjustment Knob

Bag #	Item #	Qty.	Part Description
1	11	2	Height Adjustment Knobs
2	12	6	M8 x 12L Screws/Washers
3	13	8	M8 x 55L Bolts/Washers
4	14	4	M8 x 70L Bolts/Washers/Nuts
5	15	8	M6 x 15L Screws/Washers
6	10	2	Cable Routing Ties

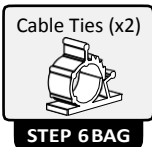

## Desk Assembly

### Step 1: Install the Height Adjustment Knobs onto the Right and Left Legs

#### LOCATE BAG LABELED 1

Contents: 2 each **Height Adjustment Knobs**

- A. Install a *Height Adjustment Knob*(11) on both the *Right Leg*(4) and *Left Leg*(5) being sure that the locking pin goes into one of the adjustment holes in each leg.
- B. Tighten the *Height Adjustment Knobs*. Be sure the Legs are adjusted to the same height when installing the *Height Adjustment Knobs*.

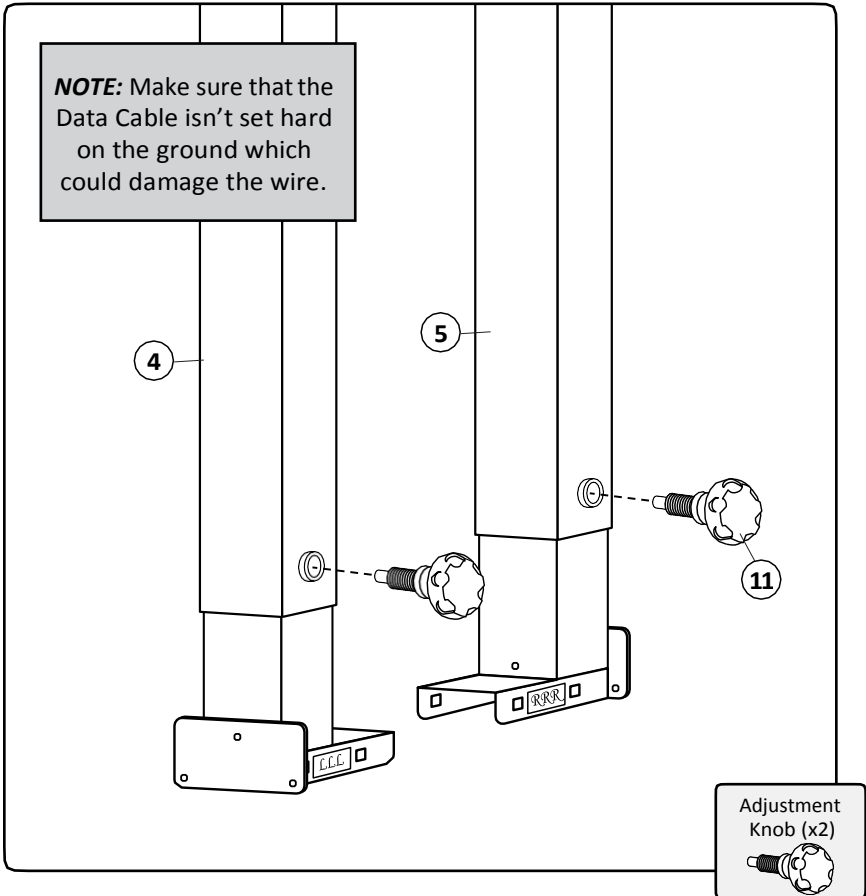

Step 2: Attach Right and Left Side Bracket

**LOCATE BAG LABELED 2**  
Contents: 6 each **M8x12L** Screws with Washers

- A. Add the *Right Desk Support Bracket(9)* to the *Right Leg(4)*. Each will have an “RRR” sticker attached for easy identification.
- B. Stand the *Right Leg(4)* shown in the illustration below and align the *Right Desk Support Bracket(9)*.
- C. Attach *Right Bracket* to the *Leg* with the *M8x12L Screws(12)*. Securely tighten with the included *5mm Allen Wrench*.
- D. Repeat for the *Left Desk Support Bracket(8)* and *Left Leg(5)*.

**NOTE:** Make sure that the Data Cable isn't set hard on the ground which could damage the wire.

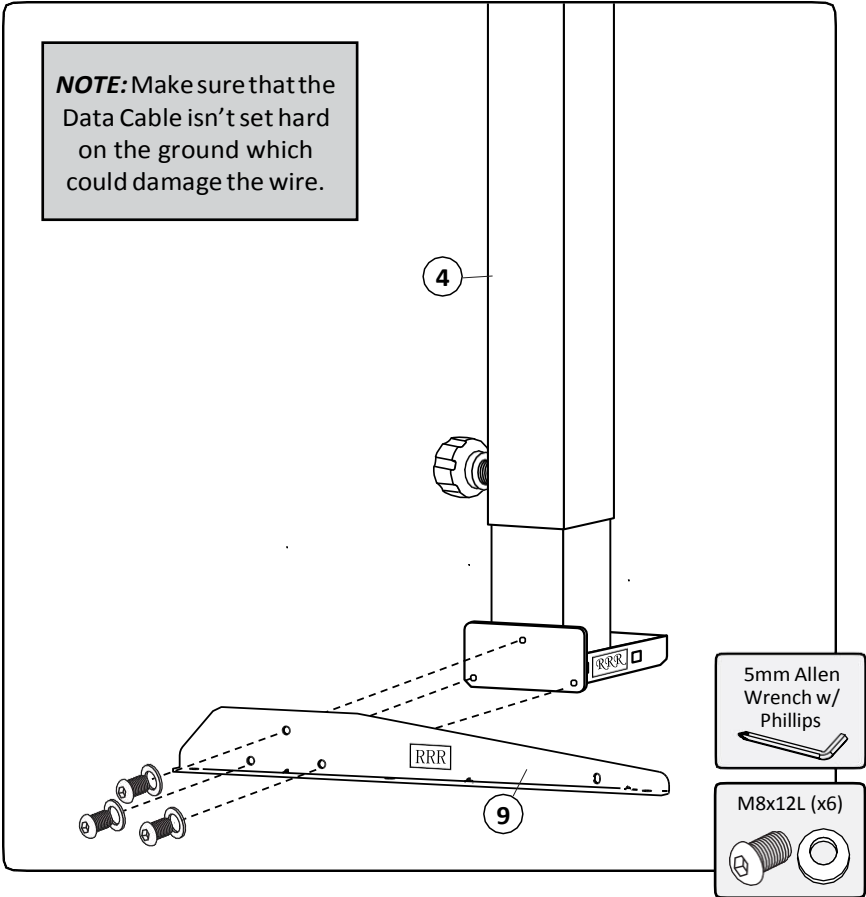

## Desk Assembly

### Step 3: Attach Base Feet

**LOCATE BAG  
LABELED 3**

Contents: 8 each **M8x55L**  
Bolts with Washers

- A. Align *Right Base Foot*(7) labelled 'RRR' with the *Right Leg*(4) and connect the wires.
- B. Push ALL extra wiring into the *Right Base Foot*(7).

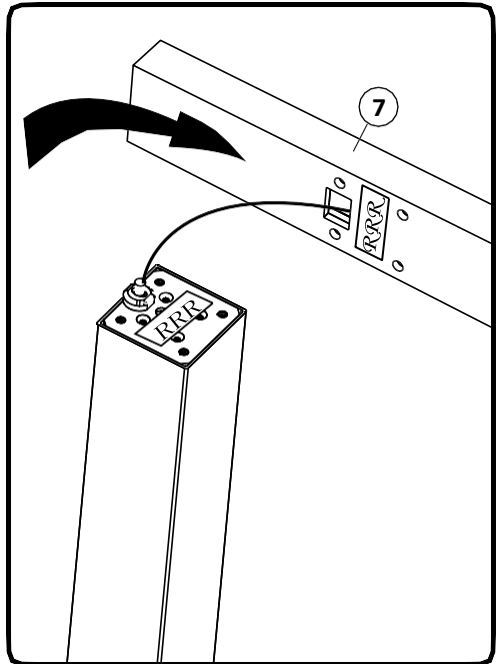
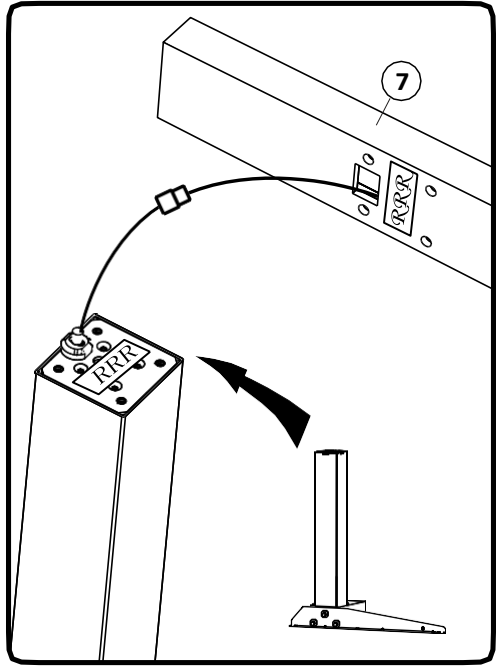

- C. Connect the *Right Base Foot(7)* to the *Right Leg(4)* with the four *M8x55L Bolts with Washers(13)*.
- D. Be careful not to damage wires inside the *Right Base Foot(7)* while installing the bolts.
- E. Tighten the four *bolts*.
- F. Tip the left post on its side.
- G. Repeat the same procedure on the left side.

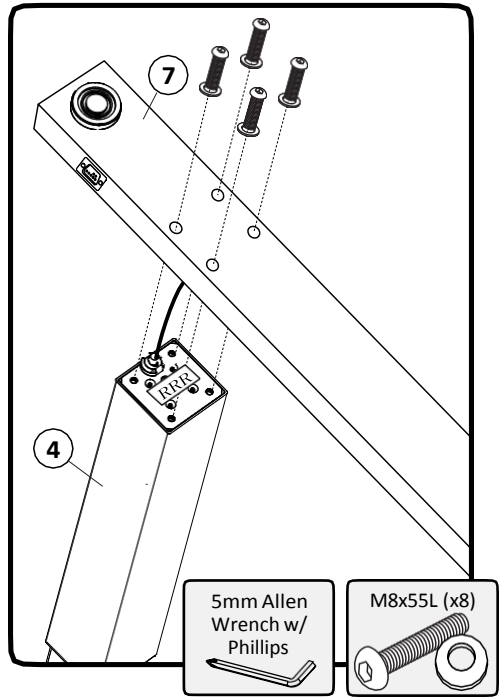

## Desk Assembly

### Step 4: Attach the Desktop Reinforcement Mounting Frame to the Right and Left Legs

#### LOCATE BAG LABELED 4

Contents: 4 each **M8x70L**  
Bolts, Washers and Nuts

- Align the *Desktop Reinforcement Frame*(1) with *Right Leg*(4). The *Desktop Mounting Flanges* should be facing up as shown in illustration.
- Carefully attach the *Desktop Reinforcement Frame*(1) to the *Right Leg*(4) by **loosely installing** the two *M8 x 70L Bolts, Washers, and Nuts*(14) as shown in the illustration. Be sure that the wire harness from the *Leg* and the *Reinforcement Frame* are routed out through the space provided.
- Connect the 7-pin wire harness cables and carefully tuck excess wire into the *Reinforcement Frame*(1).
- Repeat Step B with *Left Leg*(5).

**NOTE:** Do not fully tighten the four M8 x 70L bolts and nuts at this time. Keeping them loose will help with the next step in the assembly process.

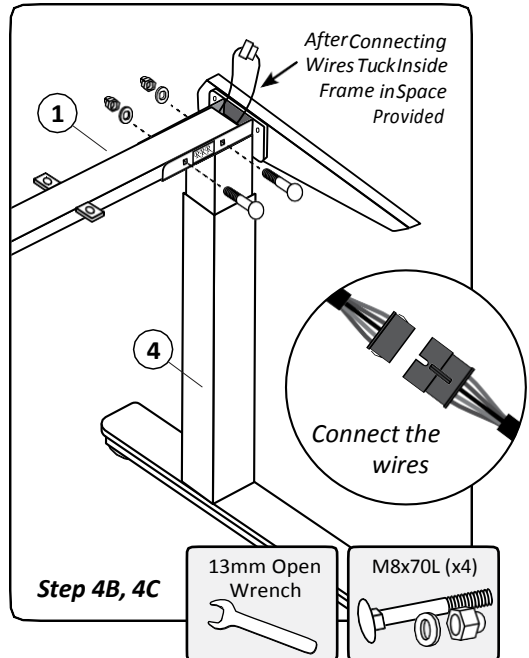
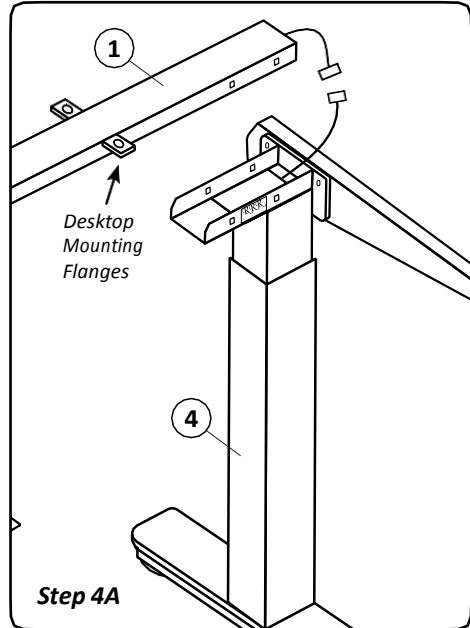

## Step 5: Attach the Leg Assembly to the Desktop

### LOCATE BAG LABELED 5

Contents: 8 each **M6x15L**  
Screws with Washers

- A. Lay the *Desktop(3)* on a clean non-abrasive surface with the bottom side up.
- B. Set the *Leg Assembly* on the bottom of the *Desktop* as shown in the illustration.
- C. Line up the holes in the *Desk Support Brackets* with the mounting holes in the *Desktop* and **loosely install** the *M6 x 15L Screws(15)* into each *Desktop Support Bracket* first.
- D. Install the remaining two *M6 x 15L Screws(15)* into the *Desktop Reinforcement Bracket*.
- E. **Tighten** all eight M6 x 15L Screws.
- F. **Tighten** the four M8 x 70L Bolts, washers and nuts previously installed in step 4 B & D.

**NOTE:**  
Be sure to line everything up exactly as shown in the illustration.

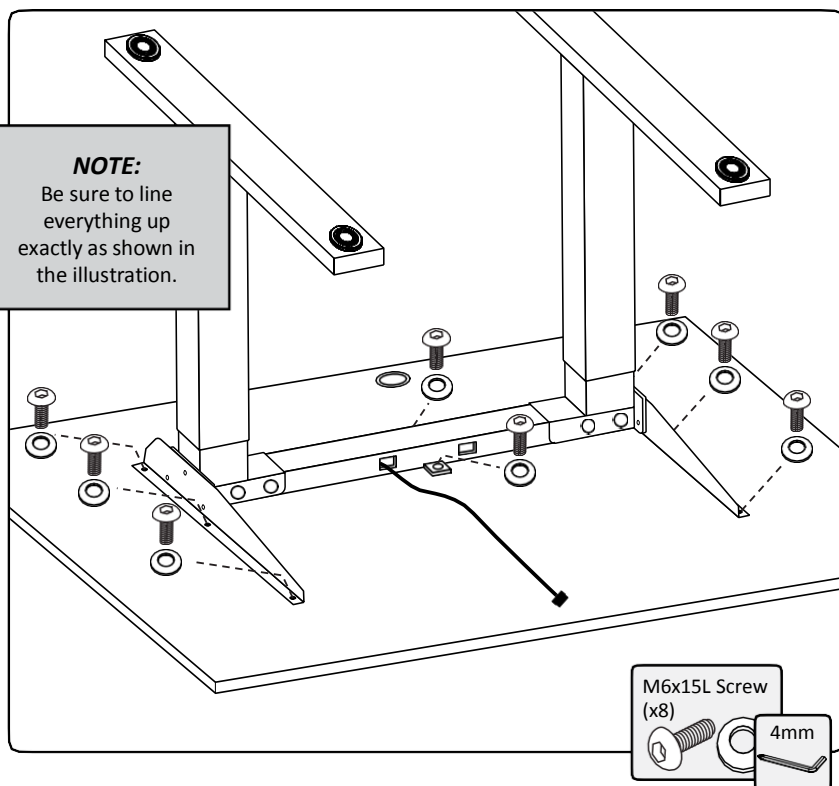



## Desk Assembly

### Step 6: Install the Cable Routing Ties

**LOCATE BAG LABELED 6**

Contents: 2 each **Cable Routing Ties**

- See illustration for placement of the two *Cable Routing Ties*(10).
- Peel the paper backing off the Cable Tie and press the tie onto the *Desktop*(3) in the locations shown in the illustration.
- Run the cable through the *Tie* and press the two *Cable Tie Halves* together

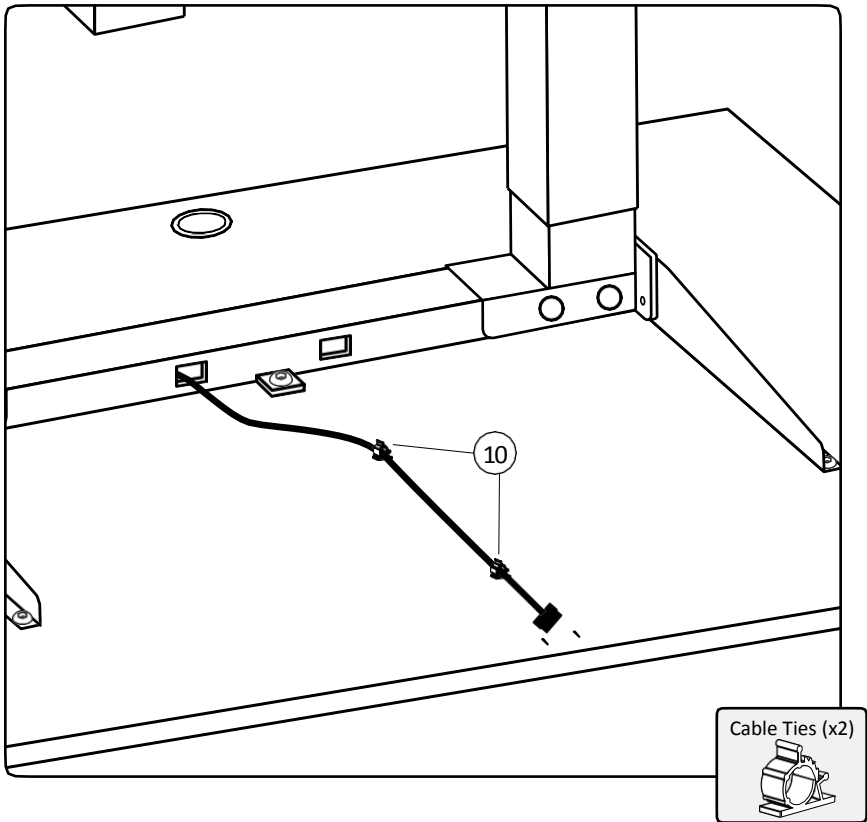

## Console Assembly

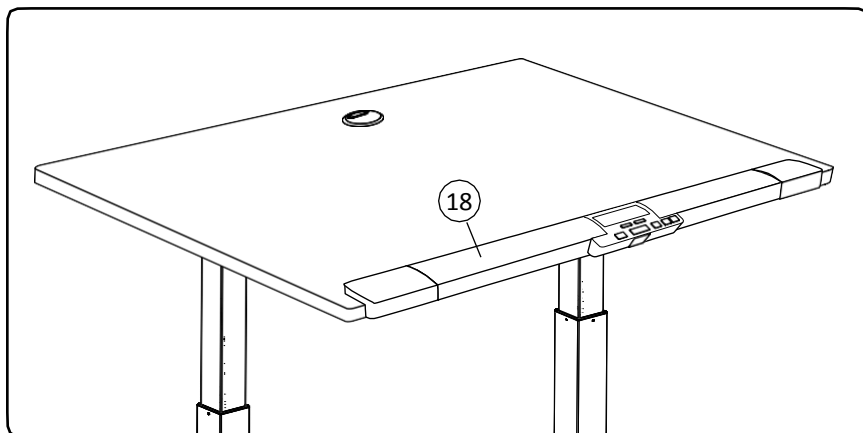

### DT5 Console Box

Item #	Qty.	Part Description
18	1	DT5 Console
19	8	#8 x 5/8" L Screw
20	2	#8 x 1/2" L Screw
21	1	Wire Harness Cover



### Step 1: Turn Upright

- A. Use 2 people to lift and turn the desk upright.

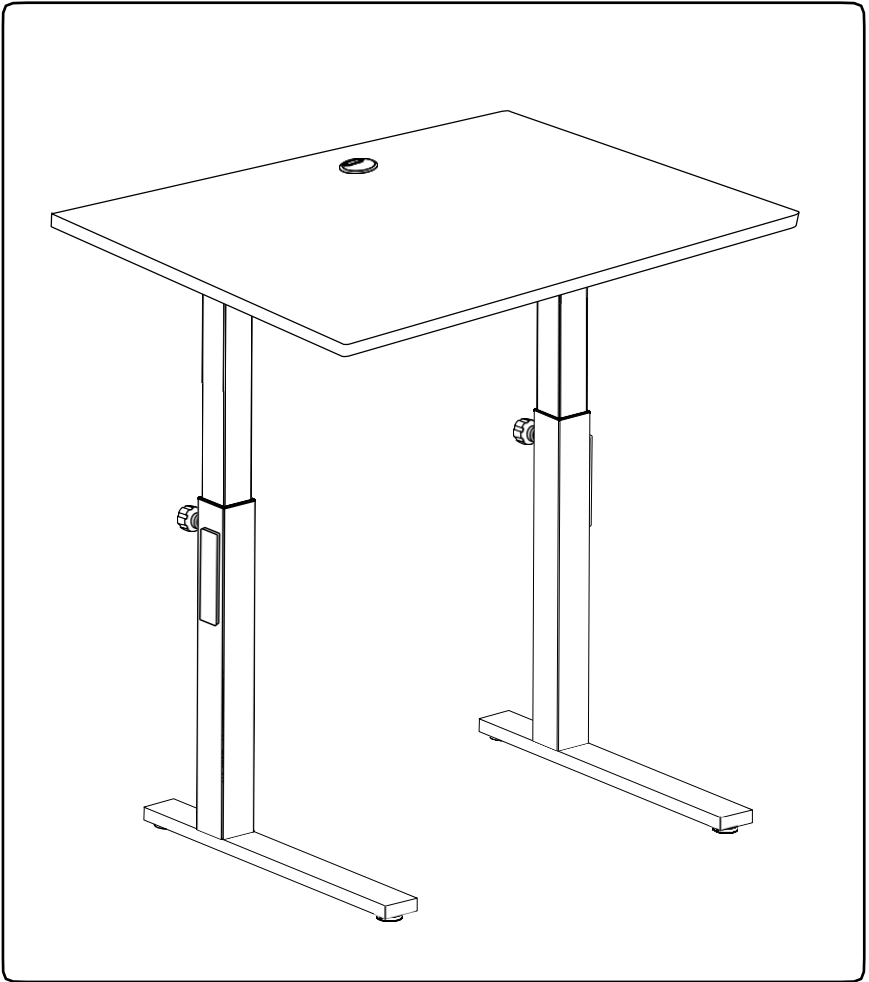

## Console Assembly

### Step 2: Console Assembly

- A. Using the *5mm Allen Wrench with Screwdriver* remove the two pre-installed screws from the back and two screws from the bottom of each console end cap so you can remove the end caps.

**NOTE:**

Notice the difference in the screws from the back and bottom as you will be replacing them back into their proper place

- B. Center the *Console(18)* on the *Desktop(3)* and attach using eight *#8 x 5/8" L Screws(19)*.
- C. Re-install the end caps with the pre-installed screws you removed in Step A.

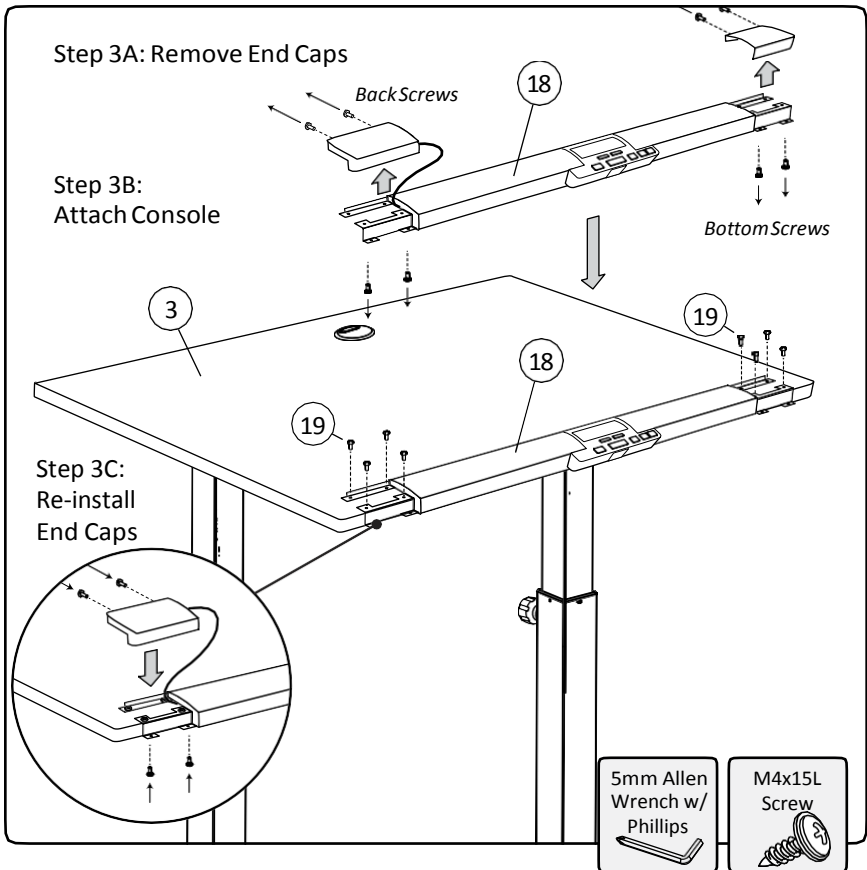

## Console Assembly

- D. Connect the Cable Connectors (E, F).
- E. Attach the *Console Wire Harness Cover*(21) to the underside of the *Desktop*(3) using two #8 x 1/2" L Screws(20). Tuck wire connections under *Cover*.

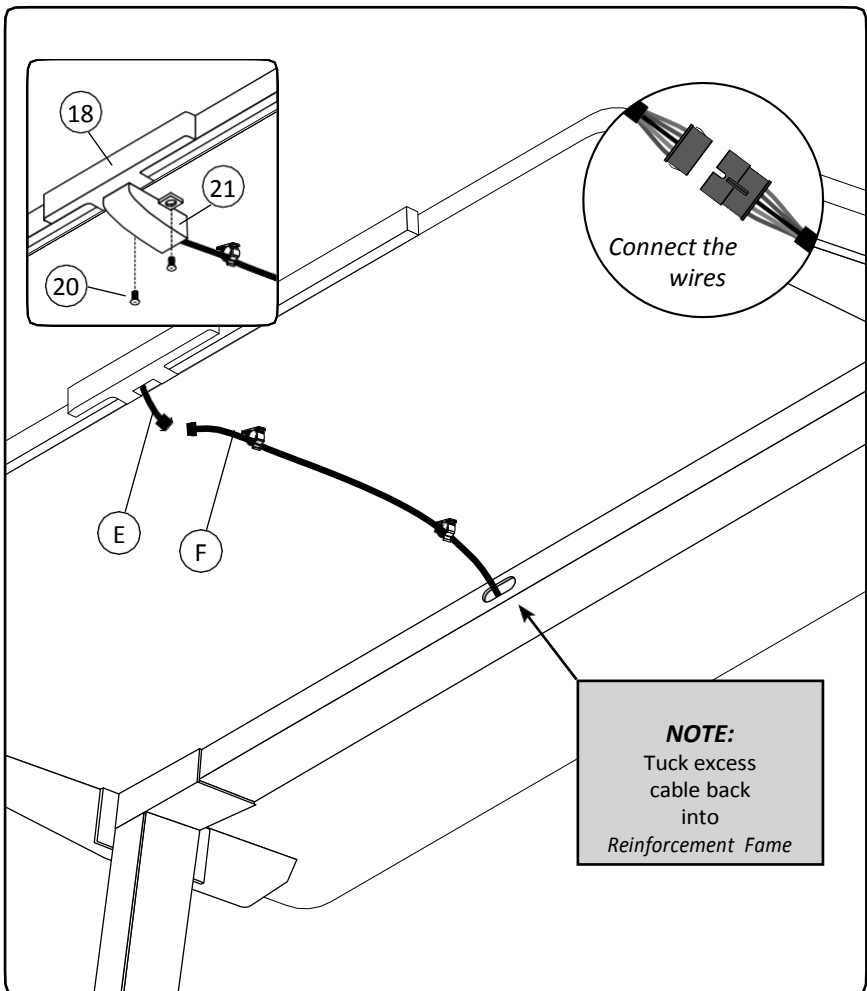

## Final Connection

### Treadmill to DT5 Desk Assembly

- A. Position the pre-assembled treadmill as shown below.
- B. Lift the rear of the treadmill and roll it forward under the desk until the treadmill is in the desired position.

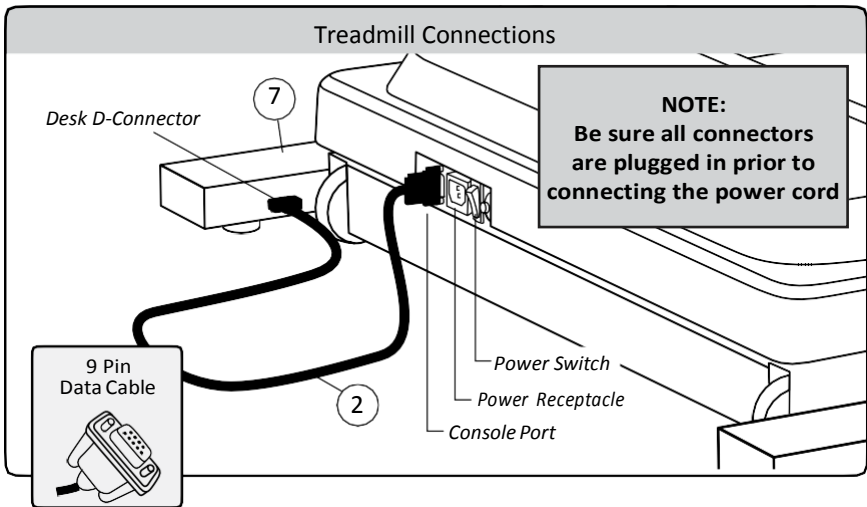
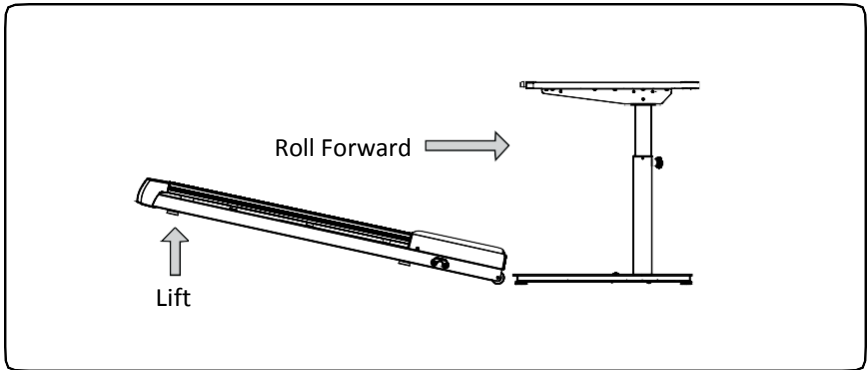

- C. Connect the 9 Pin Data Cable(2) into the desk D-Connector on the *Right Base Foot(7)* and treadmill Console Port and tighten the thumb screws.
- D. Plug the Power Cord into the treadmill Power Receptacle and wall outlet.
- F. Turn the treadmill Power Switch on.

## Leveling and Height Adjustment

### Desk Leveling

The desk needs to be leveled prior to use. The desk comes with four Adjustable Feet that can be used to level the desk and eliminate rocking. If the desk is rocking on two of the feet, adjust the necessary feet until all four feet are sitting securely on the floor.

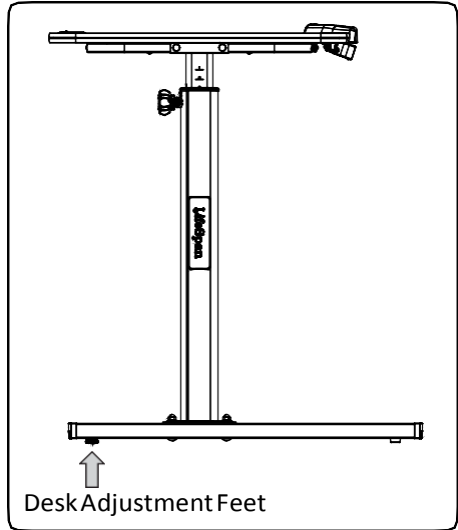

### Desk Height Adjustment

- Loosen the *Adjustment Knobs (A)* on each upright by turning it no more than two turns counter-clockwise.
- While firmly holding each side of the Desktop, pull both Adjustment Knobs out and slowly raise or lower the desktop.
- Release the Adjustment Knob as the desired level is reached. The Adjustment Knob will click into place.
- Check to make sure the desk height is set at the same level on both sides. Turn the Adjustment Knobs clockwise to lock in place.

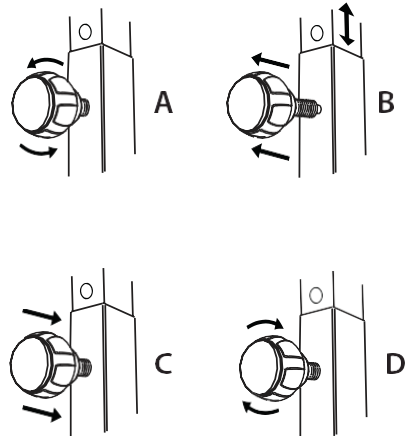

## *Treadmill Desk Operation*





# Treadmill Desk Operations

## Specifications

CONSOLE	DT5
Readouts	<i>Time, Steps, Calories, Distance, Speed</i>
Display	<i>White LED</i>
Bluetooth	<i>Yes</i>
Buttons	<i>Power, Start, Stop, Pre-Set Speed, Up/Down, Change Display, Bluetooth</i>

MECHANICS & PERFORMANCE	DT5
Speed Range	<i>0.4 - 4.0 mph* 0.6 - 6.4 kph</i>
Dimensions	<i>Optional   38" w x 29" d in – (96.52" w x 73.66 d cm) Sizes:   48" w x 29" d in – (120.65 w x 73.66 d cm)</i>
Desktop Height Adjustment Range	<i>33.5 in. to 52.5 in. with 1" Desktop 85.1 cm to a131.3 cm with 1" Desktop</i>
User Height Range	<i>Up to 6'5" Up to 195 cm</i>
Height Adjustment Method	<i>Manual</i>
Desktop Material	<i>1" (2.54 cm) thick high-density Composite Board</i>
Desktop Surface	<i>Durable Laminate</i>
Maximum Load on Desktop	<i>220 lbs 100 kg</i>

\* **Default setting is 2 mph.** Can be changed to max speed of 4 mph/3.2 kph in personal settings

### Setting the Clock

The console has a built-in clock that should be re-set to your time zone. This will allow your exercise data to be recorded correctly. There are two ways to set the time and date: through a smart phone or with the console keypad.

#### **Smart Phone Automatic Adjustment**

The clock will automatically adjust to the correct date and time if you use the LifeSpan phone app when you sync your exercise results via Bluetooth. The app can be downloaded in Google Play or the Apple iTunes store.

#### **Console Keypad Manual Adjustment**

Using the console keypad, follow these step-by-step instructions:

1. Press and hold **Up** and **Down** buttons together for one second.
2. Press the **Change Display** button once.  
\* **The display will FLASH and is ready to adjust.**
3. Use the **Up** and **Down** buttons to change the Month.
4. Press the **Change Display** again to save the Month and move to the next setting.
5. Continue this process to adjust Day, Year, Hour, and Minute.

Legend	
EH	Month
d	Day
y	Year
H	Hour
n	Minute

## Treadmill Desk Operations

### Starting the Treadmill Desk

1. Turn the On/Off toggle switch located on the front right corner of the treadmill to the On position. If this is already On, press the On/Off button on the console.
2. Make sure the Safety Key is engaged in the console.

NOTE: The display will show "—" if the Safety Key is not engaged. Please make sure that the Safety Key is fully engaged. It is possible the display will not show "—" when just partially engaged.

3. Press the Start button to start the treadmill belt. The console will start counting up from 0:00.
4. Press the Up/Down buttons to adjust speed, or use the Preset button to go directly to your preferred speed (which defaults to 1.5 mph). See the separate section on Preset, as well as the section on Settings, for more details.



### Console Buttons

1. **On/Off:** Turns on the console. When pressed again, turns off the console; the console must be in standby mode (displaying the current time) for the power off function to work.
2. **Start:** Starts the treadmill belt. Performs other functions in Settings.
3. **Stop:** Stops the treadmill belt, Pausing your use. If pressed for one second, resets the console (all data readouts are reset to zero).
4. **Preset:** When the treadmill belt is moving, changes the speed to 1.5 mph, or to a custom speed that is set in Settings. See separate section on Preset, as well as the section on Settings.
5. **▲▼:** Increases or decreases speed by 0.1 mph.
6. **Change Display:** Changes the data readout between Time (the default), Distance, Steps, Calories, and Speed. Press and hold for one second to automatically change readouts every five seconds; press again to stop this automatic change.
7. **Bluetooth:** Turns on Bluetooth communications. Phone apps available from LifeSpan can use this system to track your activity. See the Bluetooth section for more details. You can change the function of this button in Settings.

## Treadmill Desk Operations

### Preset (Speed) Button

Out of the box, the Preset button activates 1.5 mph with a treadmill.

Change the speed or resistance in Personal Settings.

This feature may be disabled in Settings, setting Preset to OFF. Default is ON.

### Bluetooth Operation

To sync your activity data with your LifeSpan app, launch the app, press the Bluetooth button, and hold your phone a couple of inches from the console. Syncing will take only a few seconds.

## Innovative Features

**Bluetooth** – The Bluetooth communications system in this Workplace Solutions console can send activity information to LifeSpan apps. Your phone must be equipped with Bluetooth 4.0 or later, also known as Bluetooth Low Energy. All iPhones and most Android phones have this.

**Intelli-Step**<sup>™</sup> – LifeSpan treadmill desks come with Intelli-Step, our exclusive step counting feature that senses each time your foot lands on the walking belt, then counts your step total on the display console. If you're in the habit of counting daily steps, or want to incorporate a daily or weekly step count goal, this feature will provide more accurate step counting than using a smartwatch or other wearable step counting device. Accuracy does require that the treadmill desk is able to detect your steps, and will be less accurate for those who walk lightly including those individuals under 100 pounds (45.5 KG).

**Intelli-Guard**<sup>™</sup> - This unique safety feature is engaged when the treadmill belt speed reaches 1.0 MPH (1.6 KPH) or faster and automatically pauses the belt 20 seconds after you stop walking, ensuring that no one else steps on the treadmill desk without noticing that it's already running. When Intelli-Guard senses that the treadmill is no longer being used, after 20 seconds the audible beep will first notify you that the treadmill belt is going to pause. This feature can be controlled in Personal Settings.

## Treadmill Desk Operations

**Personal Settings** – there are several features that can be set using our Personal Settings feature to tailor LifeSpan treadmill desks to your specific preferences. These include:

- **Maximum Speed**: Select 2MPH (3.2KPH) or 4MPH (6.4 KPH) maximum speed options.
- **Intelli-Guard Selection**: On / Off setting
- **Resume Speed**: after pressing pause, then starting again, the default belt speed will be 0.4 MPH (0.6 KPH), which is the normal starting speed. The resume starting speed can be modified to be the previous running speed.

In addition, the following features are applicable to both treadmill desk and bike desk users.

- **Audible Safety Beep**: On / Off setting. Each time the control buttons on the console are depressed, an audible beep is used as an alert that a change was made. This is designed to prevent accidental speed adjustments being made without users being aware that they may be accidentally depressing a button.
- **Bluetooth Pairing**: Manual or Automatic. The Bluetooth feature can be set to automatically sync with your phone. If the desk is used by more than one person, we suggest keeping it in manual mode and only sync your results when the Bluetooth button is depressed.
- **Metric versus Standard Readouts**: Change the display readouts for speed and distance to Metric or back to standard readouts.

**Arm Rest** – Foam padding on the front of the desk give you a comfortable place to rest your arms and provide a location to hold onto the desk to keep you located when actively engaged in other activities like walking meetings.

## Treadmill Desk Operations

### Troubleshooting

The LifeSpan Treadmill Desk is designed and manufactured to be reliable and easy to use. However, if you have a problem, these troubleshooting steps may help you find the cause.

***Problem: The console is erratic or not lighting up.***

*Solution:* Check to make sure the treadmill desk is properly plugged in. Turn the power switch off and back on again and make sure the Safety Key is in place. Make sure the connectors located in the front of the treadmill and under the desktop are fully plugged in. If the problem persists contact LifeSpan customer service.

***Problem: The treadmill motor seems strained or E1 comes up after several minutes of use.***

*Solution:* The silicone lubricant that is applied to the deck and belt is wearing down and the belt needs to be lubricated with 100% silicone spray (non-aerosol).

***Problem: The treadmill automatically pauses during a workout.***

*Solution:* The treadmill is not picking up the step count. Go into the Personal Settings section (page 34) to turn the Intelli-Guard feature off.

***Problem: The treadmill speed doesn't feel right (either too fast or too slow).***

*Solution:* Go into the Personal Settings section (page 34) and check if you are in Metric or English mode. If you are in the correct mode, contact LifeSpan customer service.

***Problem: "UART" appears in the display.***

*Solution:* Turn the treadmill desk power switch off. Unplug and re-plug the connections made in Step C on page 22. Make sure the thumb screws are properly tightened. Turn the treadmill desk power back on and check to see if it functions properly.

## Treadmill Desk Operations

***Problem:*** “dc-6” appears in the display.

*Solution:* Turn the treadmill desk power switch off. Unplug and re-plug the connections made in Step C on page 22. Make sure the thumb screws are properly tightened. Turn the treadmill desk power back on and check to see if it functions properly.

***Problem:*** The desktop surface is not level.

*Solution:* Check to make sure the base feet are on a level surface. Make sure the manual height adjustment knobs are in the same location holes on each leg.

***Problem:*** The treadmill belt is beginning to slip and needs to be tensioned.

*Solution:* Refer to the owners manual included with the treadmill base.

***Problem:*** The treadmill belt is beginning to drift to the left or right and needs to be aligned.

*Solution:* Refer to the owners manual included with the treadmill base.



# Treadmill Desk Operations

## Personal Settings

Press and hold Change Display for one second to enter Settings mode.

Press the up or down arrows to move through the various settings. Press Start to choose a setting to change.

Press the up or down arrows to move through the various choices for that setting.

Press Start to select a choice. This takes you back to settings mode, where you can move through the other settings.

Press Stop to exit Settings mode.

**Intelli-Guard** — Intelli-Guard ON/OFF.

**Speed Reset** — Controls whether, after a Pause, the treadmill resumes the most recent walking speed, or resets to 0.4 mph. If ON, the speed resets to 0.4 mph.

**Beep** — Turns off the normal treadmill beep that happens at every button press.

**Speed Limit** — The maximum speed of the treadmill.

**Pre Set** — Turns on and off the Preset feature. Turning this off is desirable in a group environment.

**Preset Speed** — Changes the preset speed from something other than the default of 1.5.

**Weight** — Changes the default bodyweight from something other than the default of 150 pounds / 70 kilograms.

**Units of measure** — Choose English (Imperial) or Metric.

**Multi-User** — Choose yes if more than one person will be using the treadmill desk.

**Bluetooth-Auto** — Choose whether to automatically pair.

**Sleep Function** — Choose whether the console has a Sleep, or Auto-Power-Off function when the console is paused. The default function is No Sleep. If you choose to enable the Sleep function, you can choose to wait 10 minutes before sleep, or 20 minutes.

Display Details

Setting	Setting Displayed	Choice 1 (Default)	Choice 2
Enter Settings mode:	SETTG	n/a	n/a
Intelli-Guard	GUARD	ON	OFF
Speed Reset:	RESET	OFF	ON
Beep:	BEEP	ON	OFF
Speed Limit:	L	2	4
Pre Set:	SET	ON	OFF
Preset Speed	SPEED	1.5	+/- 0.1
User Weight:	T	150/70	+/- 1
Units of measure:	UNITS	ENGL	(M)TRIC
Multi-User:	USER	NO	YES
Bluetooth-Auto:	BT-A	OFF	ON
Sleep	SLEEP	NO	10/20

***TR800B/TR1200B/TR5000B – DT5***

Treadmill Base – Treadmill Desk

---