

Kore™ Teen/College Adjustable Wobble Chair (18" - 25")

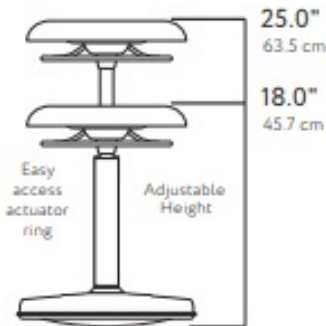

Kore™ award-winning products are designed to create a better life environment. Kore™ patented design allows a rocking motion while sitting which will strengthen one's core (lower back and stomach) with daily use.

- Increases "Secondary Focus" which allows for clearer thinking.
- Seated activities are no longer sedentary.
- Exercises legs, back, and abdominal muscles and relieves soreness/stiffness in one's back.
- Ideal for students of all ages, sizes and heights.
- Patented anti-roll safety ring on base prevents tip-overs and falls.
- Gentle-rounded, stable base moves with person and rests naturally upright.
- Soft padded cushion for extra comfort.
- 360 easy-access actuator ring to raise and lower the seat.
- Rubberized coating is non-skid, non-scratch and grips most surfaces.
- Kore™ Wobble Chairs are available in all 50 states, Canada and Europe.
- Kore™ offers a 3-YEAR WARRANTY on adjustable wobble chairs.

Specifications

Seat

Diameter 14"
Plastic seat with textured rubber

Base

Diameter 15"
Black powder-coated stamped steel with vinyl cover

Piston

Ring operated, Non-rotating cylinder
Chrome finish

Max load weight

350 Lbs (159 kg)

Item weight

15 Lbs (6.8 kg)

Carton weight

16.3 Lbs (7.4 kg)

Carton dimensions

17 x 16.5 x 11 in
(43 x 42 x 28 cm)



Keep moving while sitting!

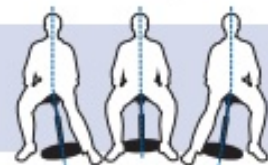

Rock Stretch Balance Swivel

The ideal seating solution for the teen student at home or the dorm-bound college undergrad. Keep your body moving while your mind stays focused and on task.



Item#
KOR7600

Color
Black

UPC Codes
6-32201-17600-2

Kore Design, LLC
1200 County Rd, Rt 523
Flemington, NJ 08822
(912)559-5673 (912)559-5670
info@korestool.com
www.korestool.com