

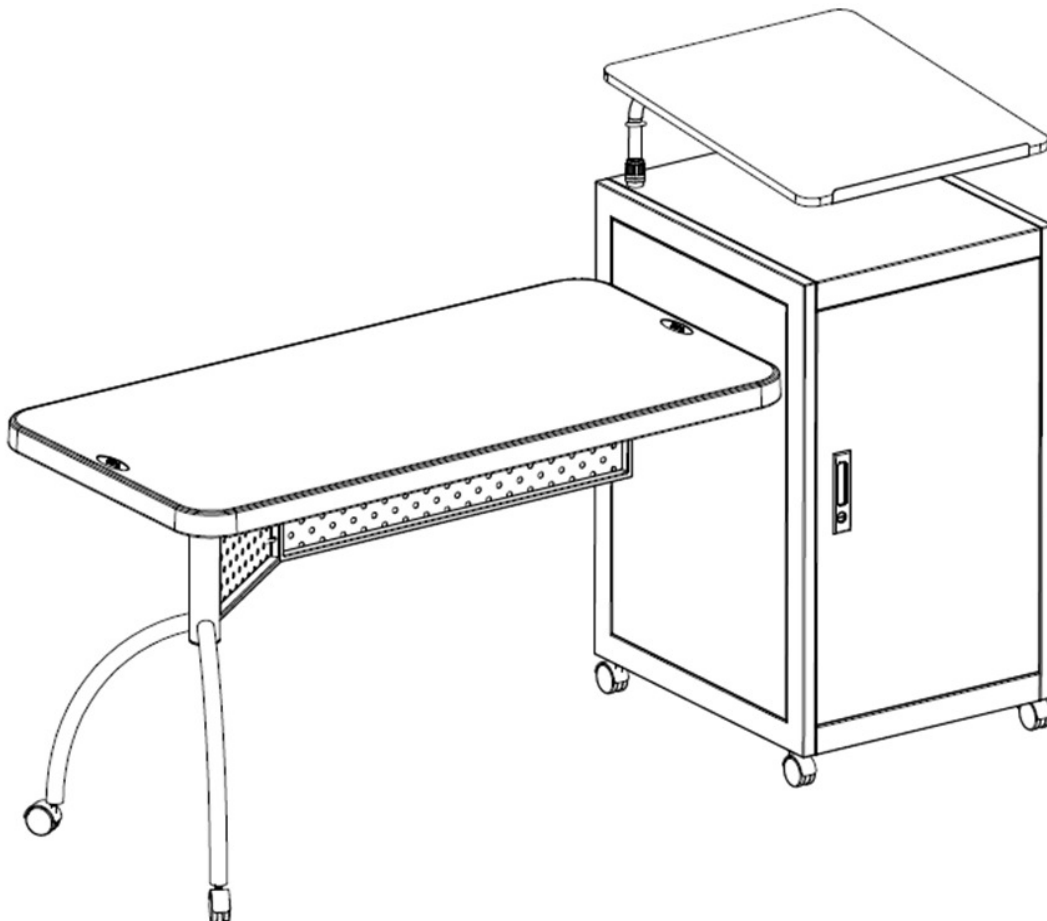











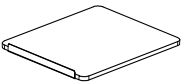



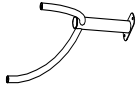
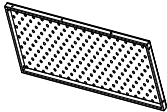

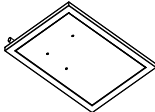
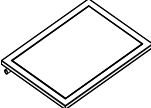
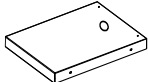
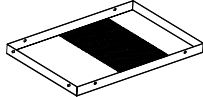
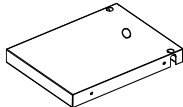
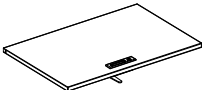









EduPod

Assembly Instructions



MODEL # EDPD

Begin by identifying all the parts and hardware.

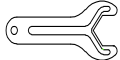
<p>A</p>  <p>Lectern Top 1 PC</p>	<p>B1</p>  <p>"L" shaped Tube 2 PC</p>	<p>B2</p>  <p>Cross Tube 1 PC</p>	<p>C</p>  <p>Desk Surface 1 PC</p>	<p>D</p>  <p>Leg Assembly 1 PC</p>	<p>E</p>  <p>Long Mesh Modesty Panel 1 PC</p>
<p>F</p>  <p>Small Mesh Modesty Panel 1 PC</p>	<p>G</p>  <p>Left Panel 1 PC</p>	<p>H</p>  <p>Right Panel 1 PC</p>	<p>I</p>  <p>Base Panel 1 PC</p>	<p>J</p>  <p>Rear Panel 1 PC</p>	<p>K</p>  <p>Top Panel 1 PC</p>
<p>L</p>  <p>Door Panel 1 PC</p>	<p>M1</p>  <p>Shelf 1 PC</p>	<p>M2</p>  <p>Shelf 1 PC</p>	<p>N</p>  <p>Hinge 2 PCS</p>	<p>O-1</p>  <p>Plastic Coupling 2 PCS</p>	<p>O-2</p>  <p>Plastic adjusting cap 2 PCS</p>
<p>O-3</p>  <p>Grommet 4 PCS</p>	<p>P</p>  <p>Non-Locking Caster 3 PCS</p>	<p>Q</p>  <p>Locking Caster 3 PCS</p>	<p>R</p>  <p>Screw M5X9 2 PCS</p>	<p>S-1</p>  <p>Screw M6X12 12 PCS</p>	<p>S-2</p>  <p>Screw M6X15 2 PCS</p>
<p>T</p>  <p>Screw M6X20 7 PCS</p>	<p>U-1</p>  <p>Screw M6X28 4 PCS</p>	<p>U-2</p>  <p>Screw M6X35 2 PCS</p>	<p>V</p>  <p>Screw M8X16 3 PCS</p>	<p>W</p>  <p>Screw M4X11 12 PCS</p>	<p>X</p>  <p>Washer 1.0X0.2X0.13 9 PCS</p>
<p>Y</p>  <p>Washer 1.0X0.2X0.17 3 PCS</p>	<p>Z</p>  <p>Wrench 4mm</p>	<p>Z1</p>  <p>Screw 1 PC</p>	<h1>Parts List</h1>		

Cabinet Assembly:

Step 1:

Begin by identifying right side panel (Part H) and lay it on a soft clean surface with the inside facing upwards. Identify the top panel (Part K) and align the two holes on the side of the top panel with the two holes on the side panel as shown in the illustration below. (Thread the small pole at the edge of the side panel into the small cutout at the edge of the top panel.) Use two bolts S-1 to attach the two panels together. Use the included allen key to tighten the bolts.

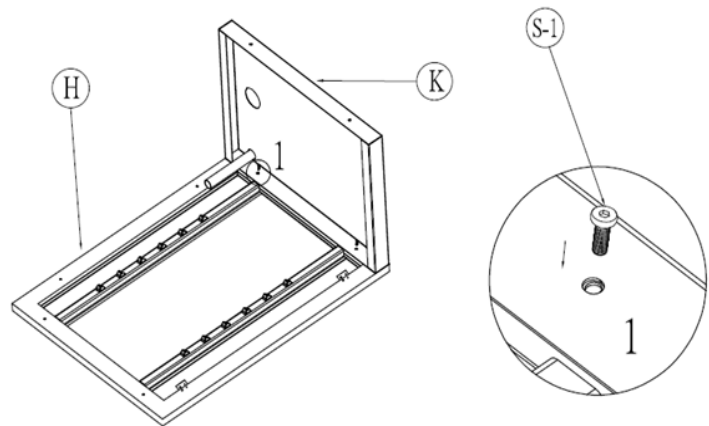

Step 2:

Place the two attached panels on their side and attach the left side panel (Part G) by repeating the assembly method of Step 1. Align the two holes on the edge of panel K with the holes on the side panel G. Use two bolts (Part S-1) to attach the two panels together.

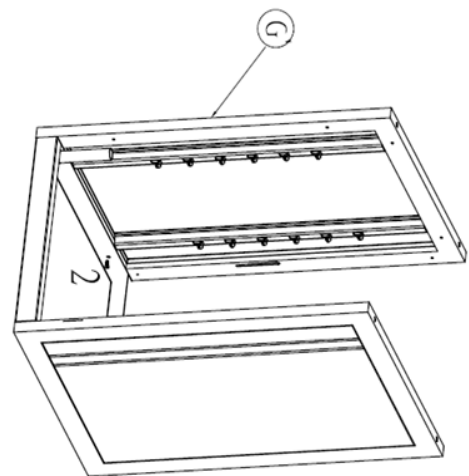

Step 3:

Identify the rear panel (Part J) and insert it between the two side panels. Align the two holes on each end of the back panel with the two holes on each end of the two side panels. Use four bolts (Part S-1) to attach the back panel to the two side panels. Use the included allen key to tighten the bolts.

Important:

- (a) The back panel should be placed between the two side panels, closer to the grommet hole on top panel K.
- (b) The rear panel J should be assembled with the mesh portion closer to the top panel (Part K).
- (c) The rear panel J should be installed with finished side facing the outside.

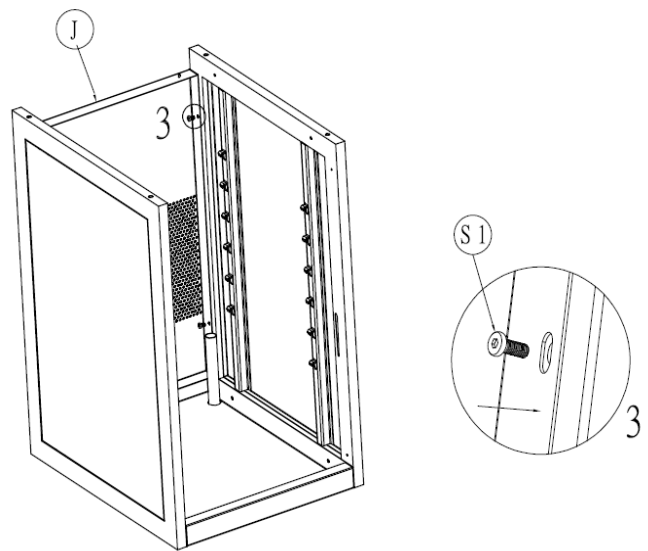

Step 4a:

Identify the base panel (Part I) and place it on the bottom of the unit between the two side panels and under the rear panel. Be sure to place the bottom panel so the grommet is close to the rear panel and the finished side of the base panel is facing the inside of the cabinet. Align the four holes on the side of the base panel with the four holes on the bottom portion of the side panels. Use four bolts (Part S-1) to attach the base panel in place.

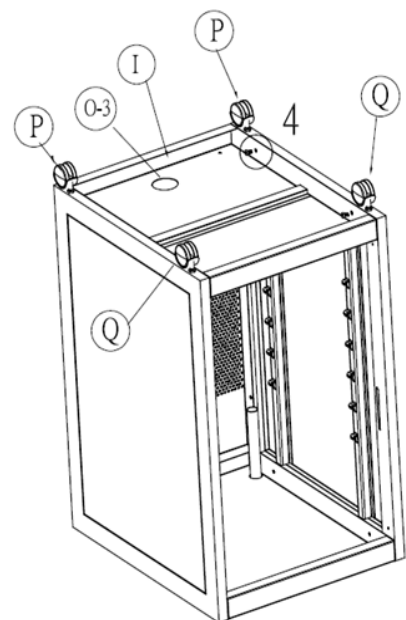

Step 4b:

Identify two of the plastic grommets (Part O3) and insert them into the holes on the top panel (Part K) and base panel (Part I).

Step 5:

Identify two locking casters (Part Q) and two non-locking casters (Part P) and attach them to the bottom of the two side panels by inserting the caster stems into the embedded nuts. Use the provided wrench to tighten each caster properly.

Important: The two locking casters (Part Q) should be installed closer to the front of the unit and the two non-locking casters (Part P) should be installed at the rear of the unit as shown in the illustration below. See illustration .

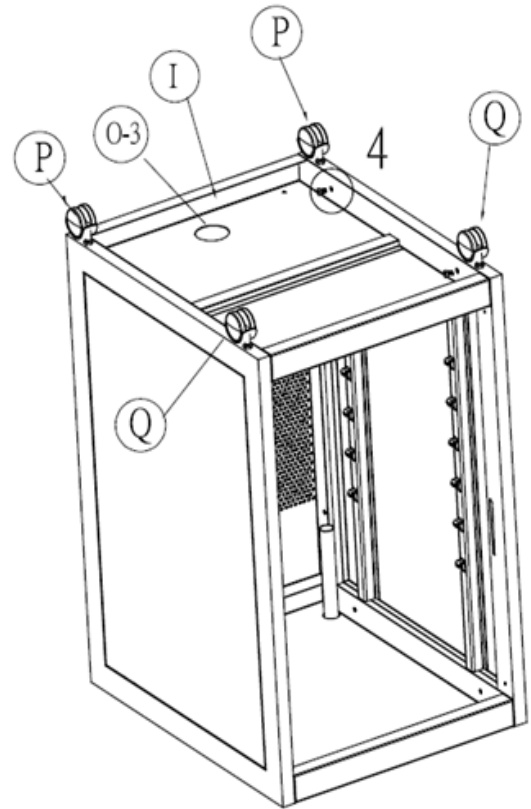

Step 6a:

Turn the unit right side up and lock the two casters so the unit will not roll around. Continue by identifying the door panel (Part L) and lay it on a clean flat surface facing upwards. Identify the two hinges (Part N) and attach them to the door by aligning the holes on the sides of each hinge with the two holes on the side of each hinge mounting hub on the door panel. Be sure that the arm of the hinges is hanging over the side of the door panel. Use two bolts (Part W) to secure each hinge to the door.

Step 6b:

Identify the eight holes on the edge of the side panel H. Align the 2 hinges with the holes and use 4 bolts (Part W) to secure each hinge to the side panel. See below illustration. One person will need to hold the door in place while a second person assembles the hinge to the side panel.

Note: Use the two adjusting screws (screw 1 and 2) in the hinge to adjust the door to fit flush in cabinet.

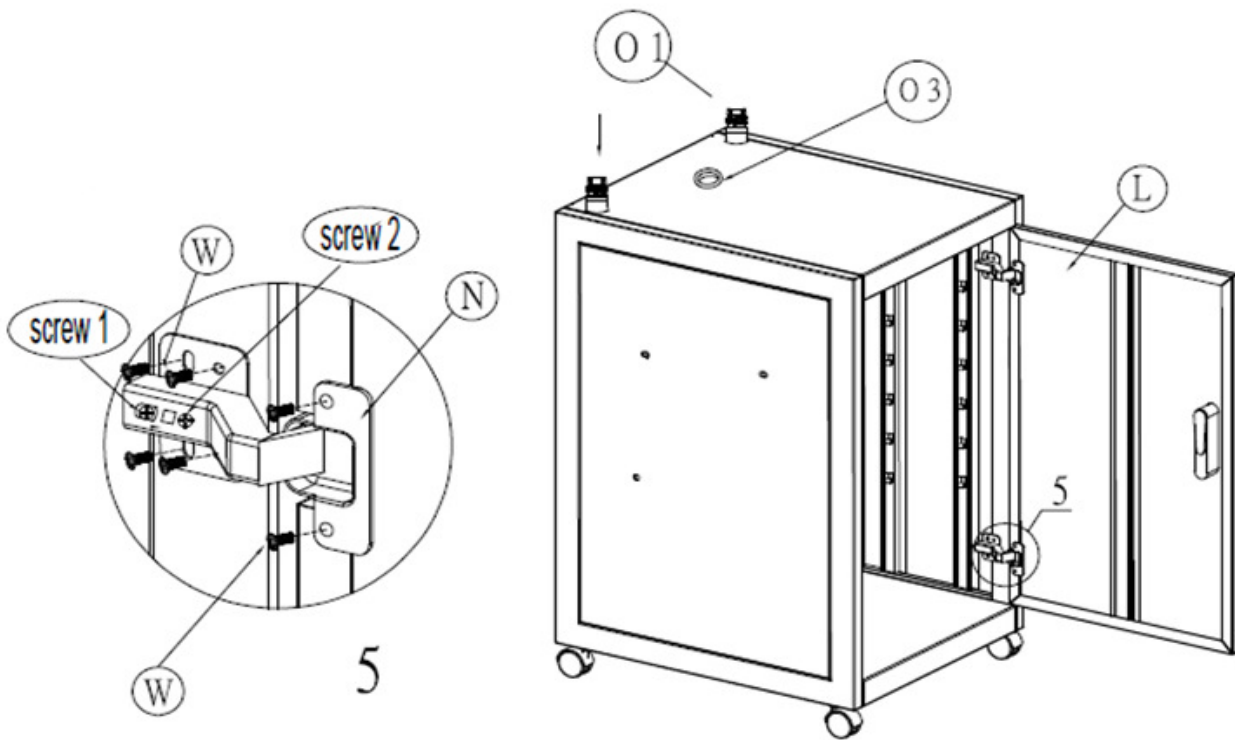

Step 6c:

Identify the two threaded couplings part O-1 and slide them over the two poles protruding from the top panel as shown in the illustration. **Align the notch on the inside of the cap with the tab on the pole.**

Press them down carefully, as far as they go without cracking the plastic.

Step 7:

Lectern Assembly

Identify the center tube Part B2 and the two “L” shape tubes Part B1. Place the center tube between the two “L” tubes and attach them together with two bolts (Part U-2) as shown in the illustration below.

Identify the lectern surface Part A and lay it down with the predrilled holes facing upwards. Place your tube assembly on the surface, and align the four holes in the “L” tubes with the four predrilled holes. Once aligned use four screws (Part U1) to attach the tubes to the lectern surface. Be sure the center tube is situated in the center of the lectern.

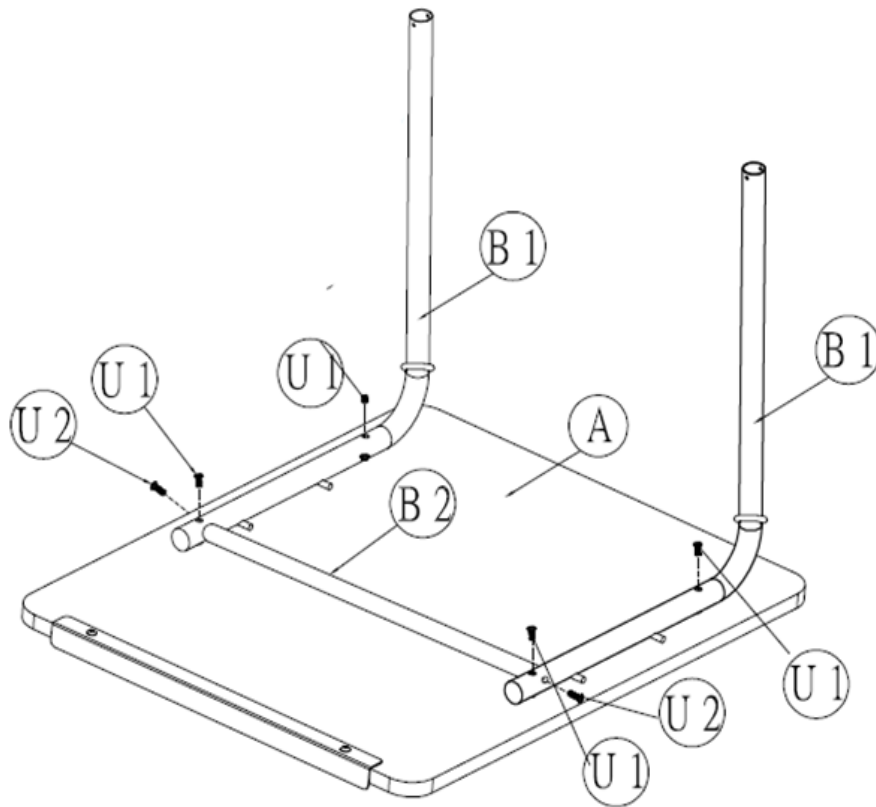

Step 8:

Identify the two plastic adjusting caps Part O2 and screw them loosely over the two plastic couplings part O1 without tightening. Insert the two "L" shaped tubes of lectern through the two caps and lower gently.

Identify two bolts (Part R) and screw them into the bottom of each of the "L" tubes (inside the cabinet) to avoid the lectern from pulling out completely when lifting the lectern.

Raise the lectern to desired height and secure in place by turn the two adjusting caps (Part O2) clockwise until tight. To adjust the height of the lectern turn both adjusting caps part O2 counter-clockwise to loosen the lectern from its position. Reposition the height of the lectern and retighten the caps to secure at the new desired height.

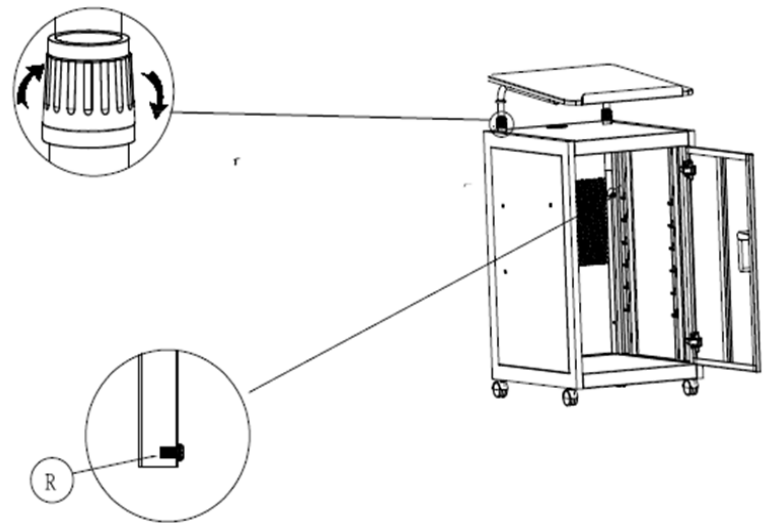
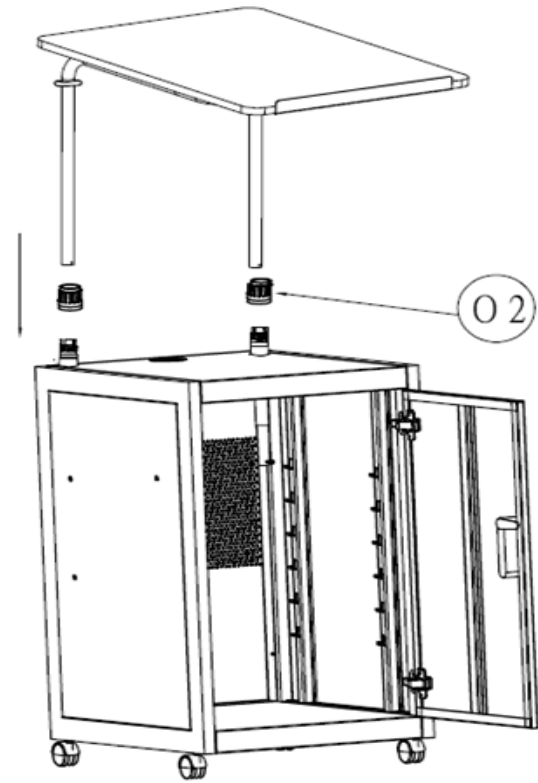

Step 9:

Identify the desk surface (Part C) and lay it down on a clean soft surface. Identify the leg assembly (Part D) and align the two holes on the leg's mounting plate with the two holes on the frame of the desk as illustrated below with the #9. Be sure that the legs are protruding towards the outer edge of the desk. Use two bolts (Part S-2) and two washers (Part X) to attach the leg assembly in place.

Step 10:

Identify the smaller mesh modesty panel (Part F) and align the two holes on the straight edge of the panel (not the angled edge) with the two holes on the leg assembly part D. Use two bolts (Part T) and two washers (Part X) to attach panel with the leg assembly. It's important that the finish

Step 11a:

Identify the long mesh modesty Panel (Part E) and align the three holes on the (long) edge of the panel with the holes on the cross bar of the desk (Part C). Once the holes are aligned use three bolts (Part T) and three washers (Part X) to attach the modesty panel to the underside of the desk. Then align the two holes on the short end of the mesh modesty panel (Part E) with the two holes on the smaller mesh modesty panel (Part F). Use two bolts (Part T) and two washers (Part X) to attach them together.

Step 11b:

Identify the two remaining casters and attach them to the bottom of each leg by inserting the caster stem into the embedded nut in each leg. Use provided wrench to tighten properly. Be sure to attach the non-locking caster (Part P) to the leg closer to mesh panel as shown.

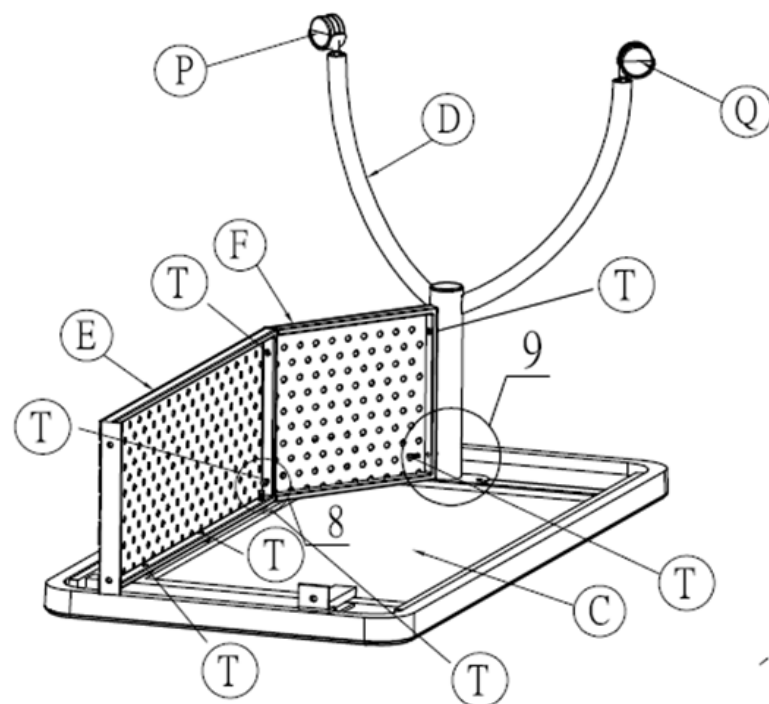



Attaching The Desk To Cabinet:

Step 12:

Turn the desk right side up and align the hole on the mounting bracket (located at the edge of the desk) and the two holes at the edge of panel (Part E) with the three holes on the left side panel of the cabinet as shown below. Use three bolts (Part V) and three washers (Part Y) and thread them through the holes on the bracket and mesh panel and into the holes on the side of the cabinet to secure in place. Use the included allen key to tighten the bolts.

Step 13:

Identify the two adjustable shelves (Part M1 & M2) and insert the grommets (Part O3) on each shelf. Slide the two adjustable shelves into the cabinet with the grommet holes at the rear of the cabinet. Be sure to use Part M-1 as the higher shelf. The shelves can be adjusted to your desired height by placing them on the shelf supports of your choice.

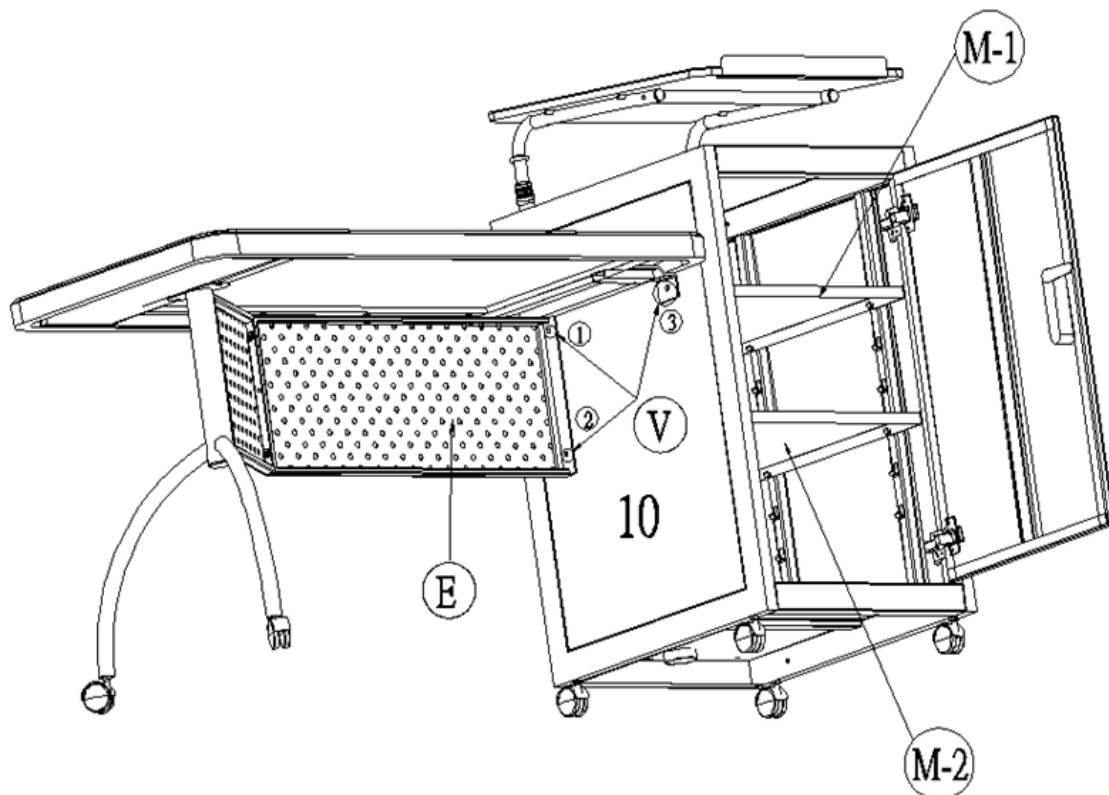



How to operate the lock and handle on the cabinet:

1. To open the door, turn the key 90 degrees clock-wise and press the key gently. The handle will then release.
2. Turn the handle to open or close the door as you wish.
3. Push the handle back in, to keep in storage position.
4. To lock the cabinet push the handle back into the storage position and turn the key counter clockwise. The handle will no longer release and the door will remain locked.

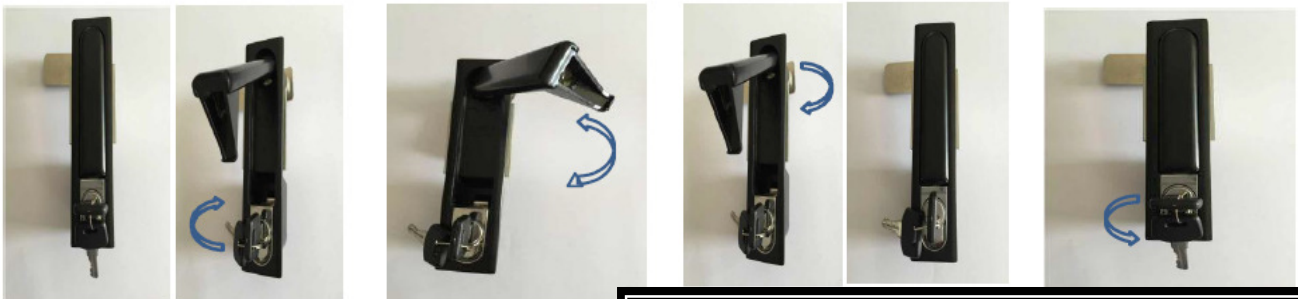

Manufactures Warranty

Dear Valued Customer,

Although extreme care goes into manufacturing and packing of this unit, mistakes are possible. If you encounter any defects or you feel that something is missing, please call our toll free customer service line at 1-800-261-4112 for courteous and immediate resolution to your problem.

Sincerely

Oklahoma Sound

Our carts undergo the most rigid and exacting test for superior quality and performance before leaving our factory. Oklahoma Sound warrants this product to be free from defective material and workmanship on this unit for five years from the date of resale by an authorized Oklahoma Sound distributor. Oklahoma Sound will replace defective parts and repair malfunctioning products under this warranty when the defect occurs under normal installation and use, provided that the unit is returned to our factory via prepaid transportation after direct authorization and approval from Oklahoma Sound. This warranty provides that examination of the returned product must disclose in our judgment a manufacturing defect. This warranty does not extend to any product which has been subject to misuse, neglect, accident, improper installation or where the serial number has been removed if defective and is given in lieu of any other warranty implied or expressed and will not cover any damage.

To enquire about any other Oklahoma Sound product please contact your dealer, or:

Oklahoma Sound

149 Entin Road, Clifton N.J. 07014 ♦ Tel : (973) 594-9000

www.oklahomasound.com ♦ info@oklahomasound.com

