



8' Standard Bench with Back Perforated-Beveled Edge-Portable Frame

601-678

Physical Details

Weight	150	Seat Height	20"
Total Boxes	3	Seat Width	12"

Component Details

Item No.	Part Number	Description	QTY
1	613-708	Bench Plank	2
2	603-942	Portable Bench Leg	2
3	126-704	3/8 x 3" Button Head Bolt	8
4	316-601	3/8 Washer	8
5	416-505	7/32 Allen	1
6	516-400	Lock Tite	1
		Total Pieces	22

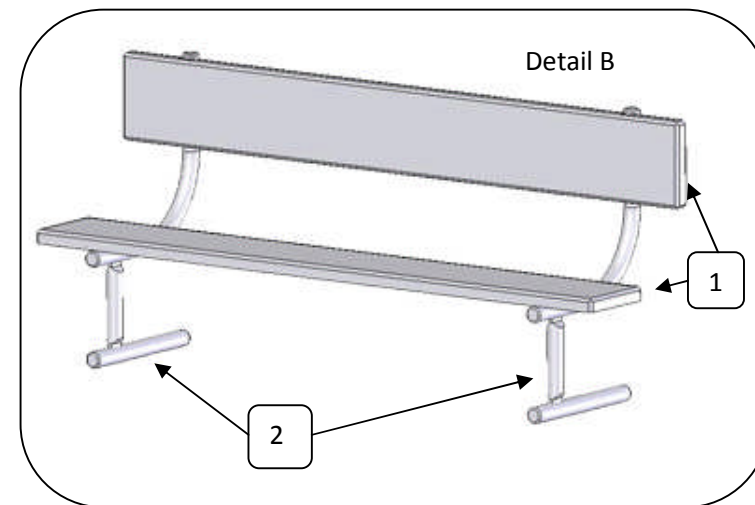
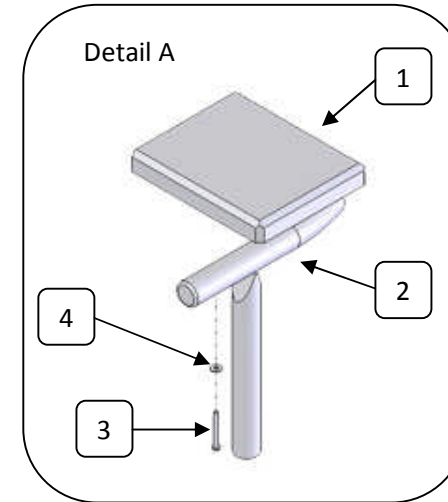
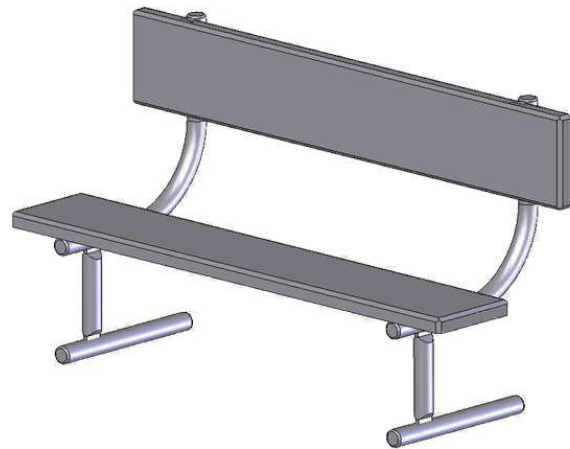



8' Standard Bench with Back Perforated-Beveled Edge-Portable Frame

601-678

Important

- Please keep a copy of these instructions in your files. There is important replacement part information in them that will assist you in the event a part is ever needed.

Assembly Information

- Verify that all parts were received by comparing the parts received to the component list on page one.
- If your product mounts to something (surface mount, in ground or wall mount) you will typically assemble the product before drilling or digging holes in order to ensure proper layout.
- CONTACT YOUR DISTRIBUTOR ABOUT ANY PARTS YOU ARE MISSING. You must report missing parts within 10 days of delivery.
- Hand-tighten all bolts during the initial assembly (unless specifically told to tighten completely in the instructions). Once the unit is fully assembled and square you should completely tighten them.
- Other than when a specific step in the assembly instructions specifies "to not apply lock tite (8)", we recommend applying a small amount to all assembly bolts.

General Maintenance

- It is recommended that you inspect the product monthly for loose bolts and broken parts. If replacement parts are needed please refer to these instructions for part numbers and descriptions then call your distributor to order replacements.

Assembly Instructions

1. Attach one of the Bench Planks (1) to one of the Bench Legs (2) by inserting two 3/8" x 3" Button Head Bolts (3) and 3/8" Washers (4) through the bottom of the Leg and into the factory installed nuts on the mounting plate attached to the bottom of the Bench Plank (Detail A)
2. Following the same procedure established in step 1, attach the same Bench Plank (1) to the second Bench Leg (2) using two 3/8" x 3" Button Head Bolts (3) and 3/8" Washers (4).
3. Attach the second Bench Plank (1) to the Bench Legs (2) following the procedures outlined in steps 1 & 2 (the second Bench plank is the back rest). Once the second Bench Plank is attached the unit will look like Detail B.
4. After you have completed steps 1-3, square the unit using a level and tighten the bolts using the 7/32 Allen Wrench (5).