

542-654 Adjustable Mounting Bracket

Page 1
Rev. 06/25/03

IMPORTANT

PLEASE READ THESE INSTRUCTIONS BEFORE COMMENCING ASSEMBLY. All equipment must be installed in accordance with these instructions. Check your shipment against Bill of Lading and Parts list. Any missing or broken parts must be reported to your distributor within 10 days of receipt of your order. When properly installed and maintained, equipment will give many years of Safe, Trouble-Free use. Periodically check for loose or broken parts. Loose bolts must be tightened and broken parts must be replaced as they can possibly create dangerous situations leading to unnecessary accidents.

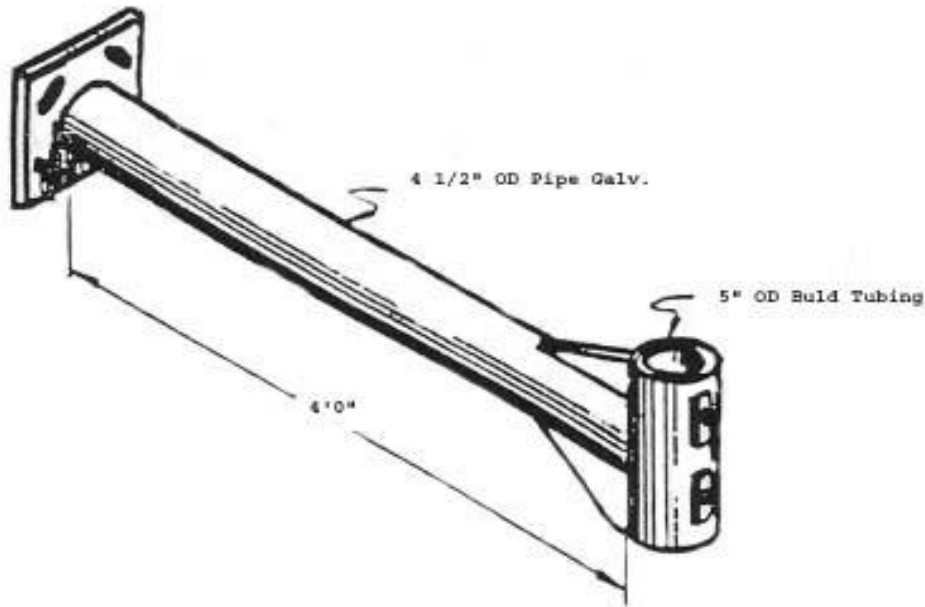

PACKING LIST

1	CTN	1		Hardware Bag
1	WF	1	543-555	Adjustable Bracket

HARDWARE BAG

2	196-803	1/2" x 3/4" Socket Set Screw
4	116-608	3/8" x 2" Hex Head Bolt
4	316-601	3/8" Flat Washer
4	216-601	3/8" Hex Nuts
1	416-400	3/4" Socket Key

1 CTN

1 WF

2 TOTAL PCS

50# Weight

Class 70

MAINTENANCE INSTRUCTIONS:

Check periodically for loose bolts, broken parts and replace immediately.