

ASSEMBLY INSTRUCTIONS
INSTRUCTIONS DE MONTAGE
INSTRUCCIONES DE ENSAMBLAJE

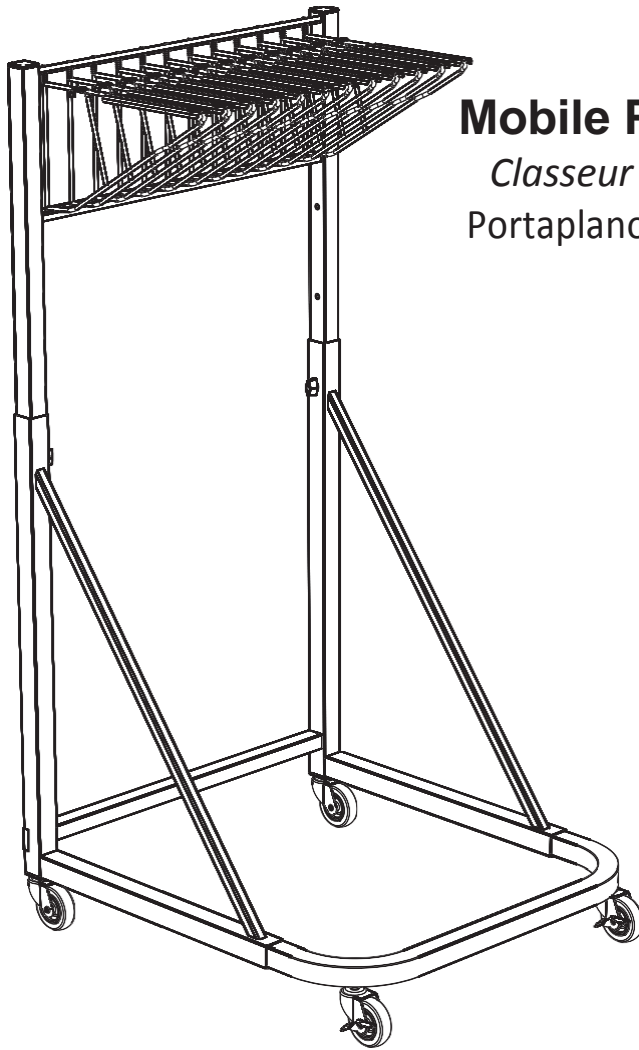

5026





Mobile Print Stand with Brackets

Classeur à dessins mobile avec supports
Portaplanos móvil con escuadras de soporte



TOOLS REQUIRED: Allen Wrench (included), Flat-bladed Screwdriver, Pencil, Measuring Tape
OUTILS REQUIS : Clef Allen (inclus), Tournevis plat à lame, Crayon, Mètre ruban
HERRAMIENTAS REQUERIDAS: Llave Allen (incluido), Piso aspas destornillador, Lapiz, Cinta métrica

Parts List / Liste des Pièces / Lista de Piezas			
Code/ Código	DESCRIPTION / DESCRIPTION / DESCRIPCIÓN	Qty./ Qté/ Cant.	Part No./ N° de Pièce / No. de Pieza
(A)	Horizontal Frame / <i>Cadre horizontal</i> / Marco horizontal	1	5020-04TS
(B)	Lower Left Frame / <i>Cadre en bas à gauche</i> / Marco inferior izquierdo	1	5020-02TS
(C)	Lower Right Frame / <i>Cadre en bas à droit</i> / Marco inferior derecho	1	5020-03TS
(D)	Vertical Frame / <i>Cadre vertical</i> / Marco vertical	1	5020-01TS
(E)	Cross Brace / <i>Traverse</i> / Barra transversal	1	5020-05TS
(F)	Pivot Bracket / <i>Support Pivotant</i> / Escuadra de soporte giratoria	12	5006-01CR
(G)	Spring (on bracket) / <i>Ressort (sur support)</i> / Resorte (en soporte)	12	5006-32NC

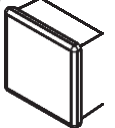
**Hardware Pack /
Paquet Matériel / Paquete Material:
5026-19NC**

<p>H</p>  <p>Set Screw <i>Vis de blocage</i> Tornillo prisionero Qty. / Qté. / Cant. 2 5020-27NC</p>	<p>I</p>  <p>Allen Wrench (not shown) <i>Clef Allen</i> <i>(non représenté)</i> Llave hexagonal (no se muestra) Qty. / Qté. / Cant. 1 5020-33NC</p>	<p>J</p>  <p>Wing Knob <i>Bouton à ailettes</i> Perilla de mariposa Qty. / Qté. / Cant. 2 5020-23BL</p>
<p>K</p>  <p>Screw <i>Vis</i> Tornillo Qty. / Qté. / Cant. 2 5020-22TS</p>	<p>L</p>  <p>Tube Plug <i>Bouchon de tube</i> Tapa de tubo Qty. / Qté. / Cant. 2 5020-29TS</p>	

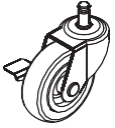
**Hardware Pack /
Paquet Matériel / Paquete
Material:
5026-99NC**

<p>M</p>  <p>Caster With Brake <i>Roue avec Frein</i> Rueda con Freno Qty. / Qté. / Cant. 2 5020-26NC</p>	<p>N</p>  <p>Caster Without Brake <i>Roue sans Frein</i> Rueda sin Freno Qty. / Qté. / Cant. 2 5020-25NC</p>
--	---

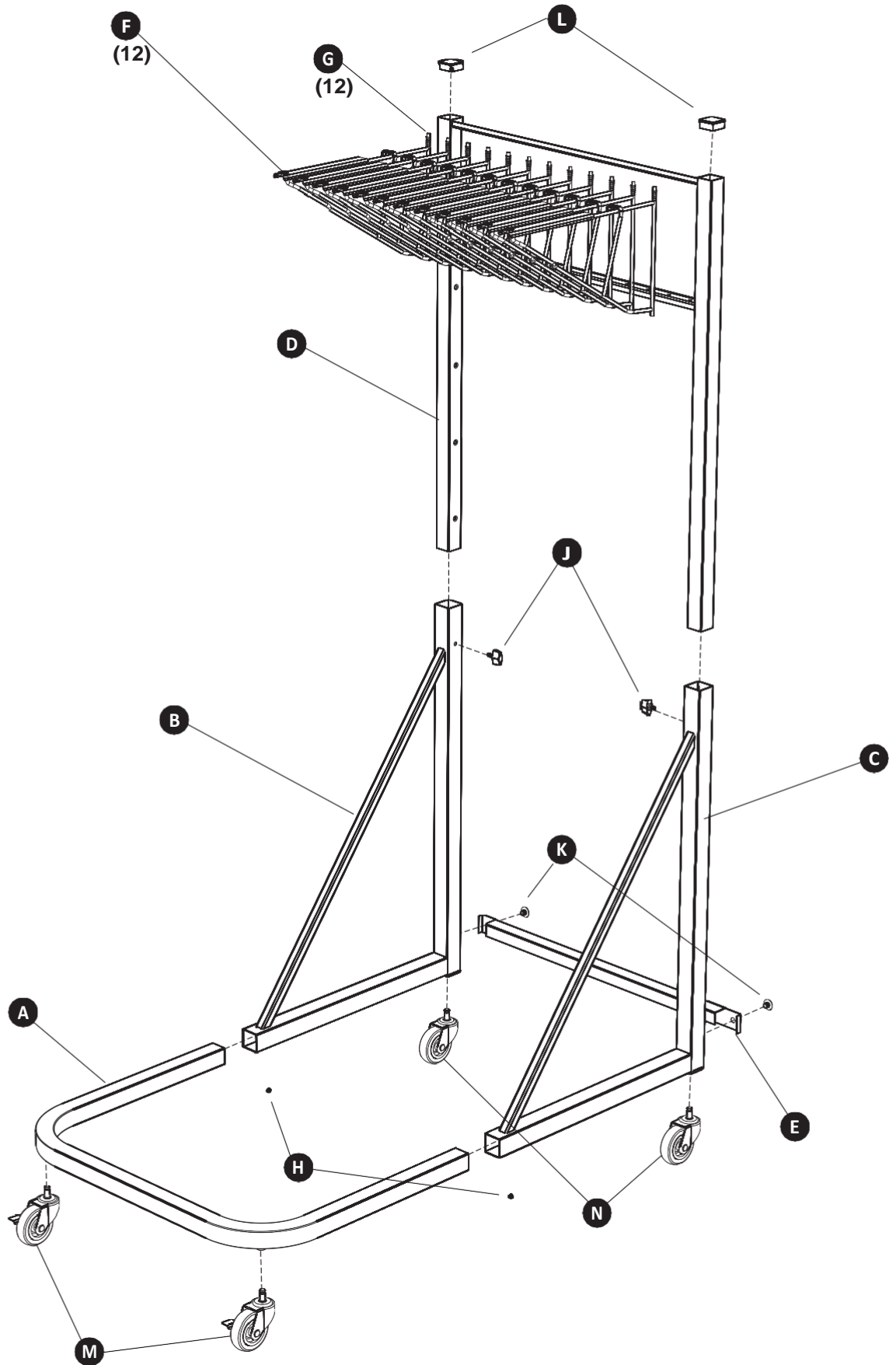

1

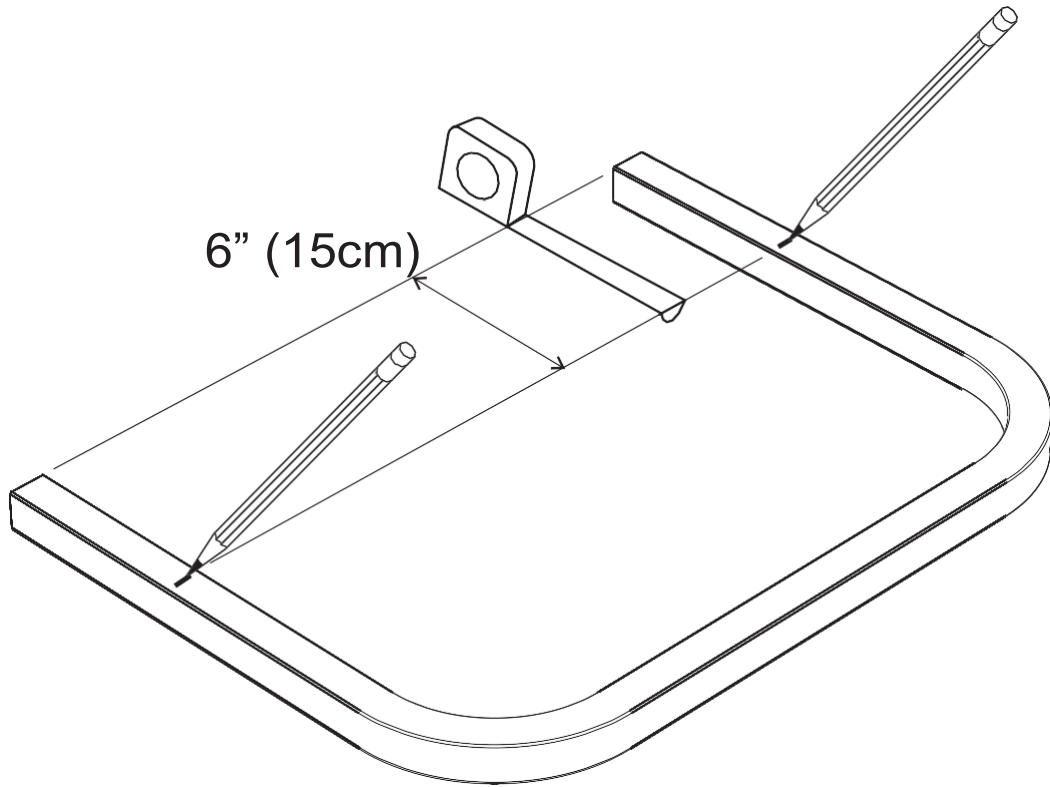

2

H

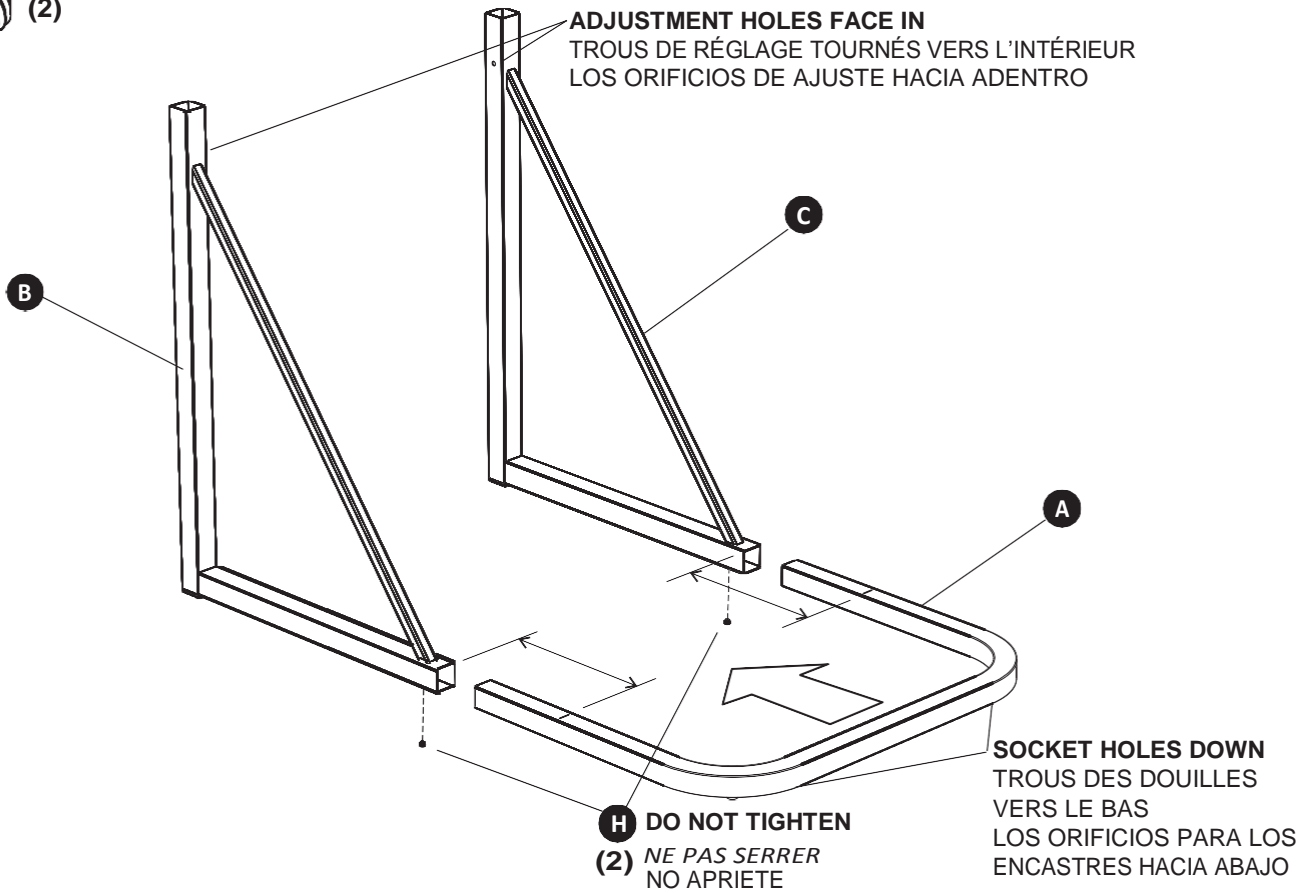

3 **K** (2)

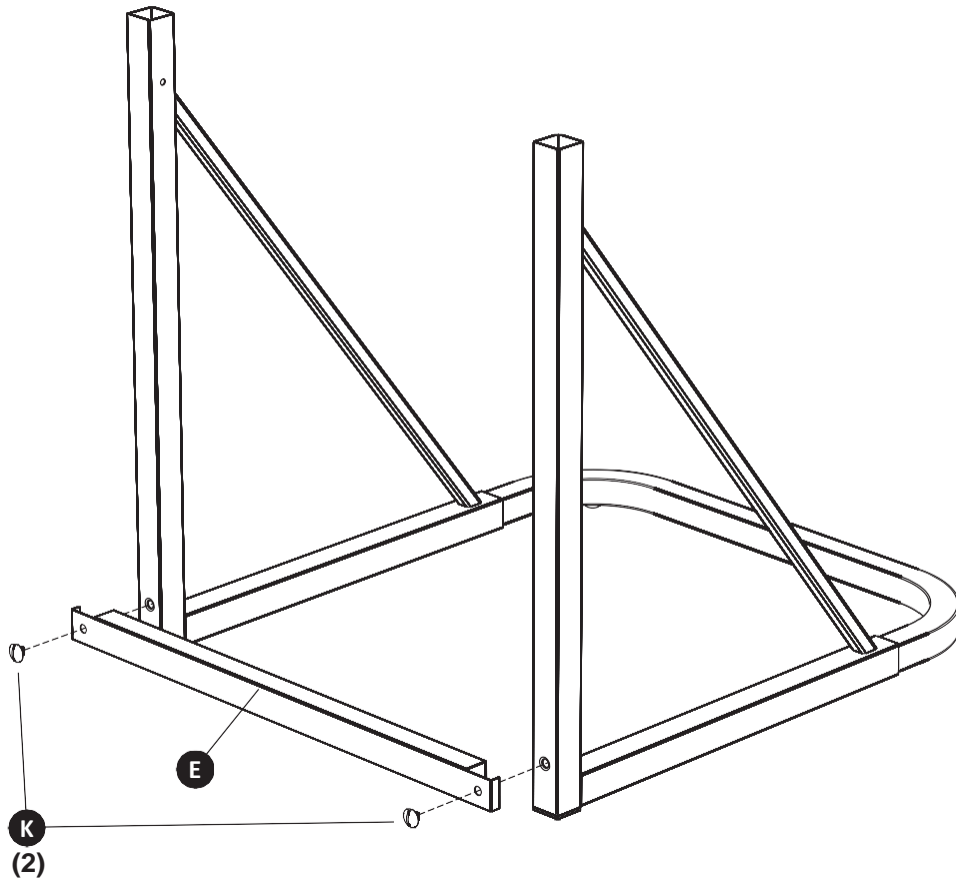

4 **J** (2)

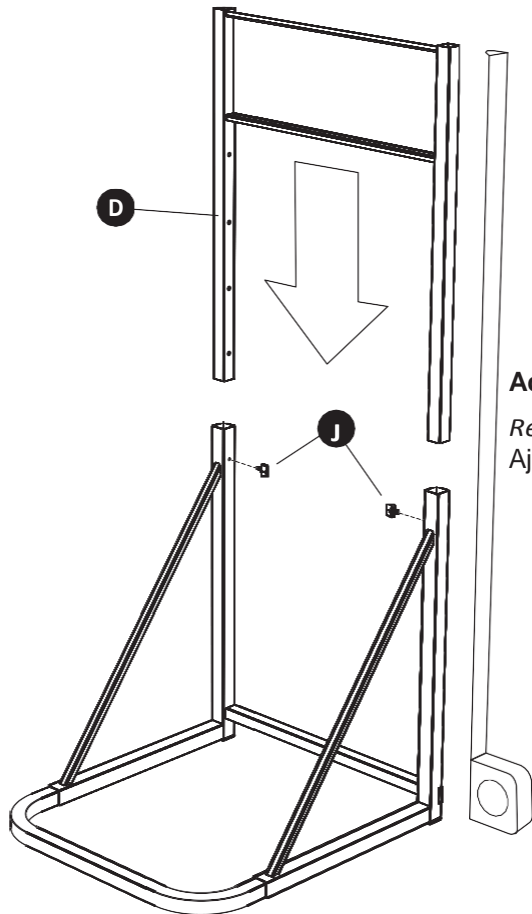

Adjust to paper size

Reglage de la taille du papier
Ajuste para el tamaño del papel

5 **L**  (2)

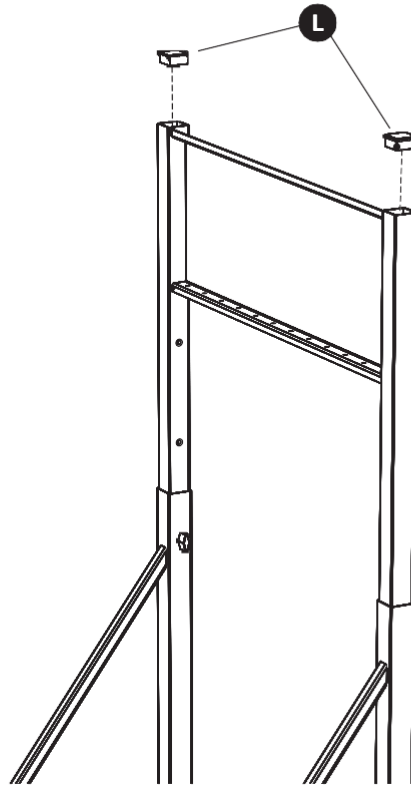

6 **M**  (2) **N**  (2)

Adjust to Paper Size and Tighten Setscrews

Reglage de la taille du papier et serrer les vis de blocage

Ajuste para el tamaño del papel y apriete los tornillos prisioneros

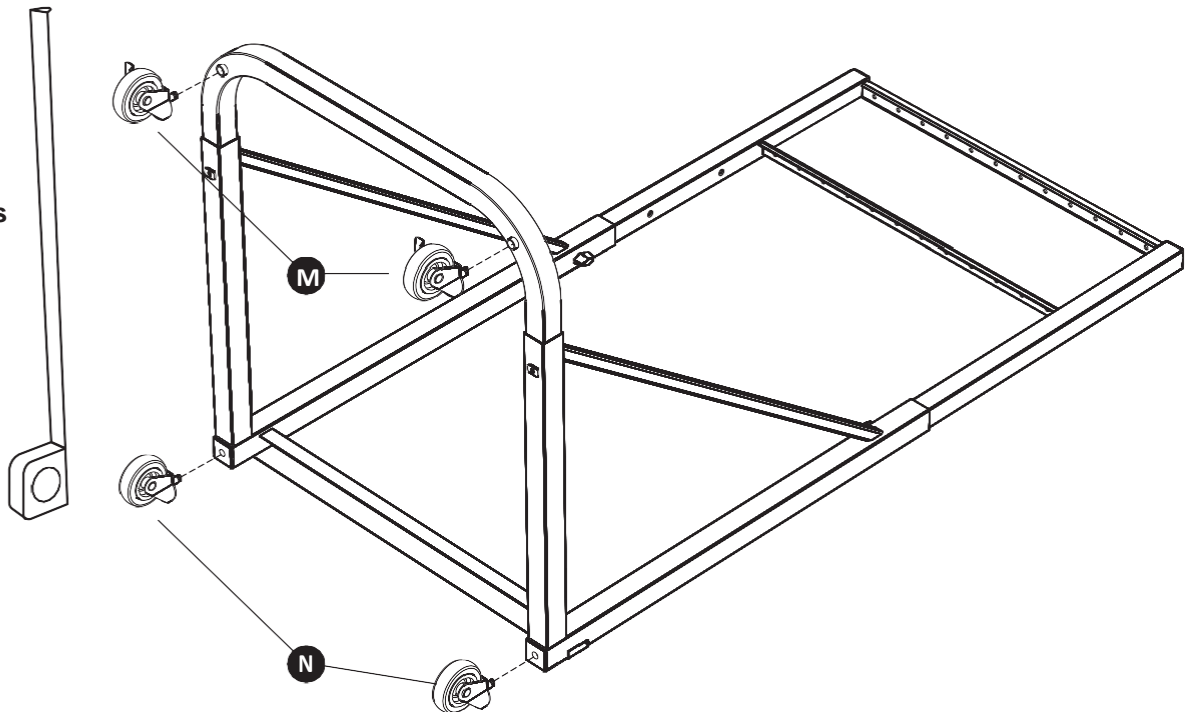

7

