

Parts Listing

A
48" Table Top
1 Unit

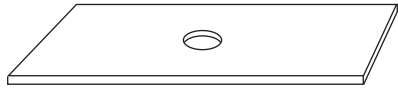

B
Upper Support Bar
2 Units

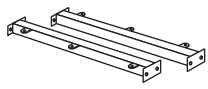

C
Lower Support Bar
1 Unit

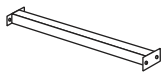

D
Table Leg
2 Units

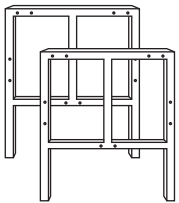

E
Seat
4 Units



F
Support Plate
4 Units



G
Seat Bracket
4 Units

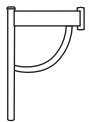

H
Table Top
Electrical Grommet
1 Unit



I
Large Hex Bolt
20 Units

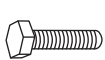

J
Small Hex Bolt
16 Units



K
6x16mm Screw
6 Units



L
6x8mm Screw
4 Units



M
Large Wrench
1 Unit



N
Small Wrench
1 Unit



O
Grommet Clips
2 Units

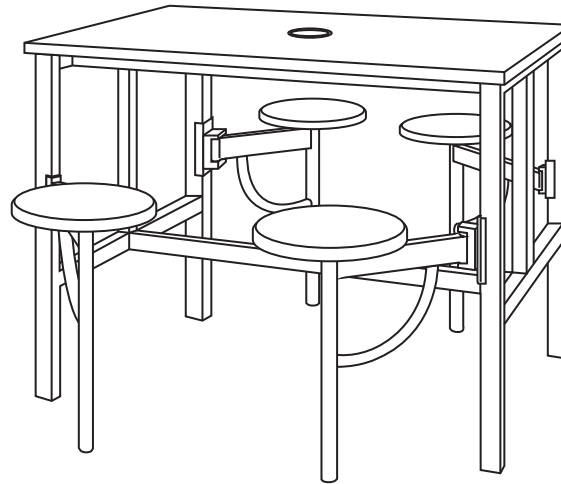

Assembly Instructions



Please read all instructions before assembly. Assembly will require 2 people.

Tools Needed: Phillips Head Screwdriver and Socket Wrench

Step 1: Attach the Upper Support Bars (B) to Table Legs (D) and secure using Large Hex Bolt (I) and Large Wrench (M), making note to keep the round brackets facing out. Hand tighten only. Attach the Lower Support Bar (C) to Table Legs (D) and secure using Large Hex Bolt (I) and Large Wrench (M). Hand tighten only.

Step 2: Install Seat Brackets (G) on the Table Legs (D) and secure using Large Hex Bolts (I) and Large Wrench (M), making sure to install the Brackets facing the correct way, as shown and noted below.

Note: Each Seat Bracket (G) should be installed with the larger cut-out of the rotating mechanism facing outward and the smaller cut-out facing inward.

Step 3: Use Small Hex Bolts (J) and Small Wrench (N) to attach Support Plate (F) to underside of Seats (E). Place Support Plate (F) into Seat Bracket (G) by pushing all the way down and secure by tightening Screw (L) on the leg of the Seat Bracket (G).

Please see page 2 to complete assembly.

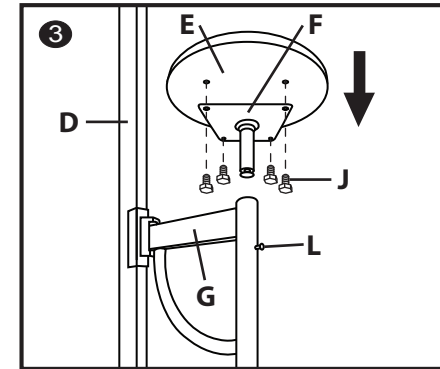
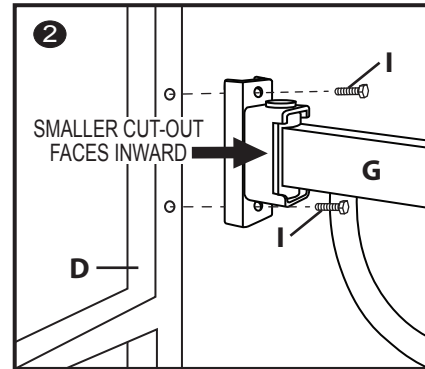
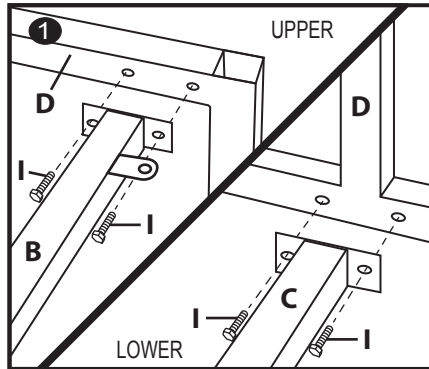

Assembly Notes:

During assembly, hand tighten screws only. When all screws are in place, you may then tighten all screws completely.

CAUTION:

1. Do not use this table as a step ladder.
2. Check for loose screws and tighten them every 6 months.



161 Tradition Trail
Holly Springs, NC, 27540
800-520-7471 (voice)
919-303-6389 (voice)
919-362-4765 (fax)
www.ofmfurniture.com
support@ofminc.com

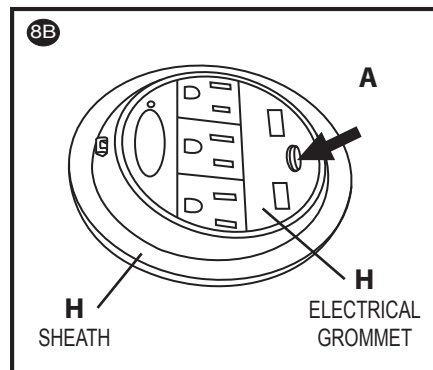
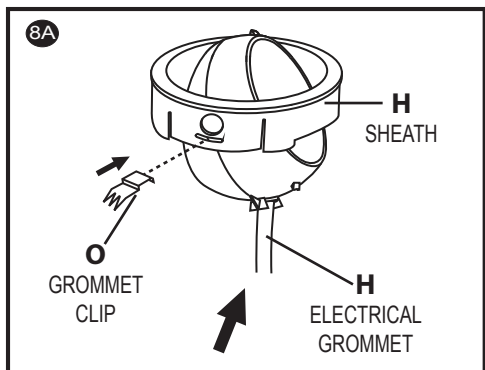
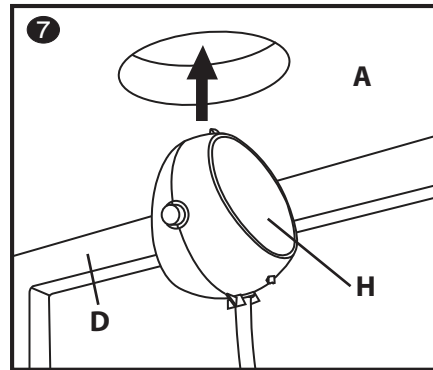
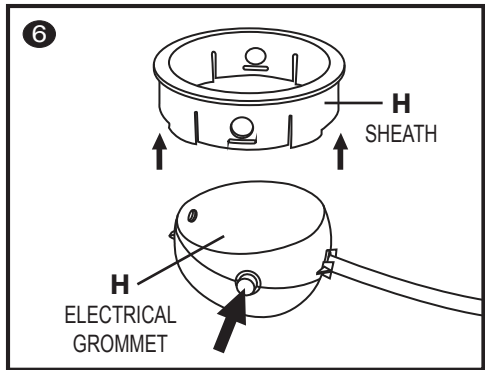
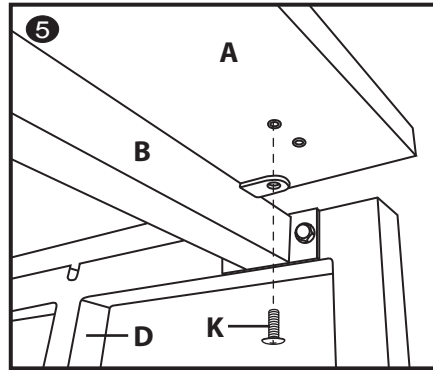
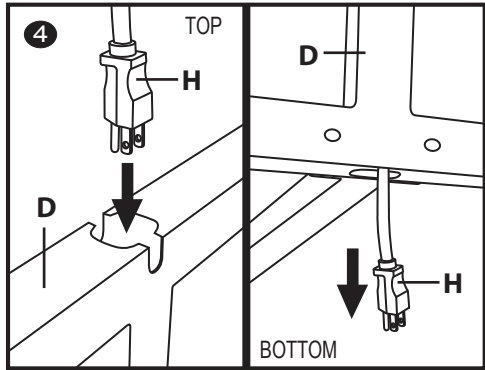

Assembly Instructions, continued



Please read all instructions before assembly. Assembly will require 2 people.

Tools Needed: Phillips Head Screwdriver and Socket Wrench

Step 4: Insert the electrical cord of the Electrical Grommet (H) down through the top of the Table Leg (D) until you can pull the other end carefully from the bottom of the Leg. Leave plenty of slack at the top, and make sure the cord rests in the small interior facing cutout which allows the Table Top (A) to sit flush on the Table Legs (D).

Step 5: Attach the Table Top (A) to the Upper Support Bars (B) by lining up the holes on the bottom of the Table Top (A) with the round brackets on the sides of the Upper Support Bars (B). Secure using 6x16mm Screws (K). Tighten all bolts on the table.

Note: For a single table, center Table Top (A) on the Upper Support Bars (B). To attach multiple tables together, see instructions below for Table Top placement.

Step 6: Carefully remove the outside sheath of the Electrical Grommet (H) by pressing the round buttons on both sides.

Step 7: Insert the Electrical Grommet (H) upwards from below the table so that it comes out on top of the Table Top (A).

Step 8: Reattach the outside sheath to the Electrical Grommet (H) by lining up the holes with the buttons, pressing the buttons and popping it into place. Insert Grommet Clip (O), as shown, below the buttons and flip upwards. Secure the Electrical Grommet (H) in the Table Top (A) by pushing it into the opening in the Top (A) and pressing firmly until it is flush. Make note that the central unit of the Electrical Grommet (H) needs to be *unlocked* so that the electrical cord hangs vertically, otherwise the Grommet will not fit into the hole in the Table Top (A).

Note: To hide or reveal the outlets, slide the small button (shown with the arrow) located on either side of the Electrical Grommet (H).

To attach multiple tables together:

To assemble 2 units together, follow Steps 1-4. To secure Table Top (A), line-up first table top off-centered so table top ends in the middle of Table Leg (D). Use corresponding off-centered holes to secure to Upper Support Bar (B). Attach second set of support bars and third leg from second unit. Attach second 48" table top off-centered so table top begins in the middle of the table leg shared with first table top. Once table top is attached, follow Steps 6-8 to complete assembly.

To assemble 3 or more units, attach all bases together as instructed above. The two outside units will use 48" tops and will follow the above instructions for assembling 2 units. All additional interior units will use a 45" top and will attach to adjacent units.

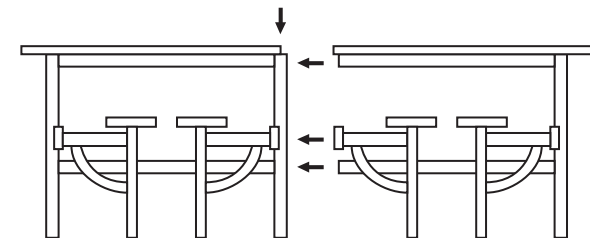

UNIT 1

UNIT 2